

SVCam-hr I6050

SVCam-HR Series / 5.5 µm Pixel

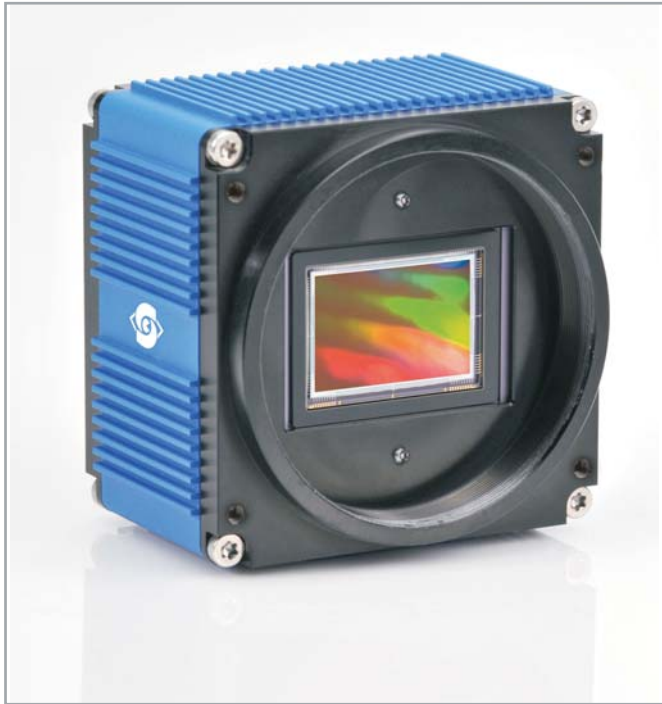

Fast 16 Megapixel Camera / 4 tap sensor architecture



This digital Machine Vision camera models have a resolution of 4896 x 3264 pixel. Combined with Kodak 4-Tap Technology it is a real masterpiece of German Engineering.

The cameras are designed to reach high frame rates at an excellent signal-to-noise ratio and are enclosed in a small housing.

Correlated Double Sampling (CDS) and 4 x 14 Bit A/D converters guarantee an excellent signal-to-noise ratio.

The internal logic allows different ways to adjust exposure time and select trigger modes including:

- > Synchronization of image capture to an external event (trigger mode)
- > "Free running" with maximum frame rate
- > Exposure time control via serial interface or by trigger pulse width
- > Longer exposure times up to under low light level conditions

The camera can work fully compliant with GigE Vision standard. In addition dual GigE complies with Static Link Aggregation (SLA) standard.



GEN*i*CAM

Technical Highlights/Technical Data

- > Progressive Scan technology
- > Resolution: 4896 x 3264 pixel
- > Synchronization:
 - "Free running" (frame rate adjustable)
 - External trigger with internal exposure control
 - External trigger with pulse width exposure control
 - Software trigger via PC
- > Housing dimensions: 70 mm x 71 mm x 49.8 mm
- > Monochrome and color sensors (Bayer Pattern)
- > 8 Bit or 12 Bit video data stream (using 14 Bit ADC)
- > Internal Memory: 256 MB RAM / 8MB Flash + 128 MB Flash
- > Pixel defect correction
- > Internal shading correction
- > Adjustable gain
- > Low offset
- > Area of Interest (AOI)
- > M42 x 0.75 Mount (optional F-Mount adapter)
- > 12V DC @ approx. 900mA consumption (model dependend)
- > Broad voltage input possible (+10V to +25V DC)
- > Operating temp. range (ambient): -10°C (non condensing) to +45°C
- > Full 2 years warranty

SVS-VISTEK GmbH

82229 Seefeld/Germany
Tel. +49-(0) 81 52-99 85-0,
Fax +49-(0) 81 52-99 85-79
info@svs-vistek.com
www.svs-vistek.com

Scale your vision.

Overview

SVCam-hr16050		GigE Version	
Camera Type	hr16050XFLGEA	hr16050XFLGEC	
Resolution	4896 x 3264	4896 x 3264	
Frame Rate (Hz, max.)	10.8* (4 tap)	8* (4 tap)	
Pixel (μm^2)	5.5 x 5.5	5.5 x 5.5	
CCD-Size Equivalent	32.36 mm diag.	32.36 mm diag.	
Exposure Time internal	17 μs - 1 sec	17 μs - 1 sec	
Exposure Time external	17 μs - ∞	17 μs - ∞	

* 4 x 50 MHz, max.) X = Monochrome, X = Color
 Cameras make use of high performance CCD made by **TrueSense Imaging, Inc.**, formerly **Kodak** (USA). For more camera types see our SVCam-HR product overview.

Dimensions [mm]

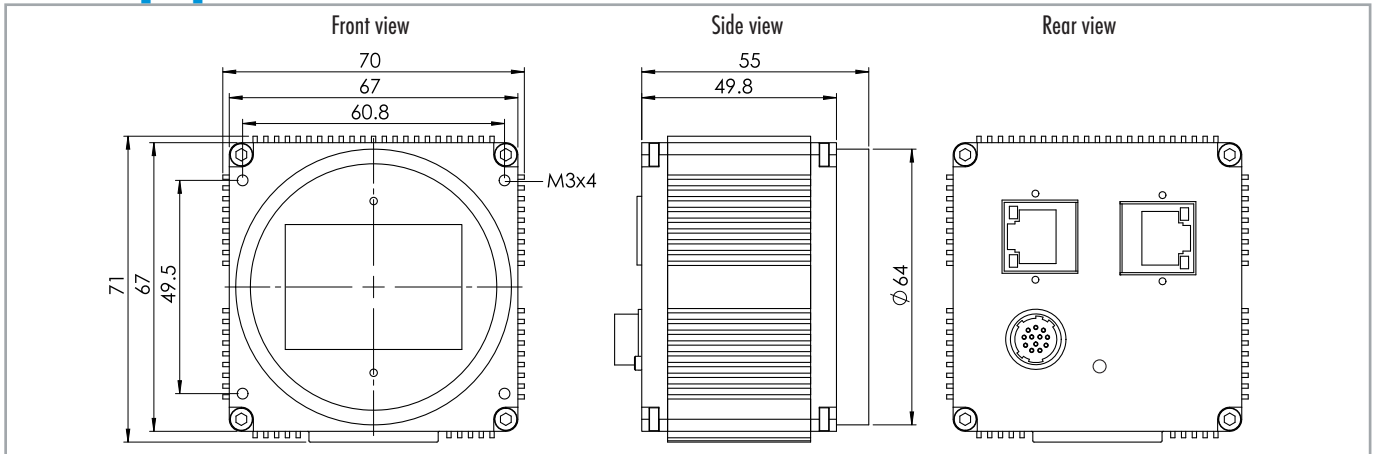

Operation Modes

Free Running/Fixed Frequency

In this mode the camera creates all sync signals itself. Camera is connected to PC and will create images immediately.

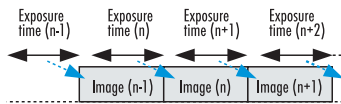

External Trigger, Internal Exposure Control

The camera needs an external trigger to output images. The exposure time is set by the internal logic inside the camera.

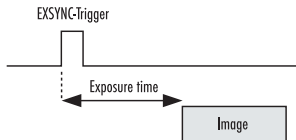

External Trigger, External Exposure Control

The camera needs an external trigger to output images. The exposure time is determined by the pulse width of the trigger signal and can be changed from frame to frame.

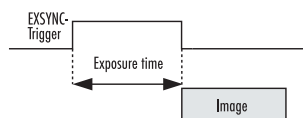

Software Trigger (GigE only)

The PC sends a command to the camera in order to get data. Internal logic is set for the exposure time. Jitter must be observed.

Connector pin-out

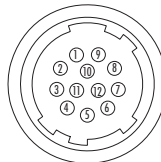

- | | |
|------------------------|------------------------------------|
| 1 VIN- (GND) | 7 OUT1 (open drain max. 24V, 0.3A) |
| 2 VIN+ (10V to 25V DC) | 8 OUT2 (open drain max. 24V, 0.3A) |
| 3 RXD (RS232) | 9 IN3- (RS422) |
| 4 TXD (RS232) | 10 IN3+ (RS422) |
| 5 IN1 (0-24V) | 11 OUT3+ (RS422) |
| 6 IN2 (0-24V) | 12 OUT3- (RS422) |

Configuration Software

The SVCam cameras come with our "SVCapture"-software, which allows easy interactive setup of all camera parameters. The program runs under Windows XP/7 but also 64 Bit mode. Linux is supported as well. A XML file compliant with the GenICam standard is supplied with the camera. The free SDK and API coming with the camera allows easy integration into an application without involving a frame grabber.

Ordering Guide

- | | | |
|----------------------|----------------------|----------------------------|
| Monochrome: | Color: | |
| hr16050MFLGEA | hr16050CFLGEA | (max. 10.8 Hz / 8 Bit) |
| hr16050MFLGEC | hr16050CFLGEC | (max. 8 Hz / 8 and 12 Bit) |

Option: M58 to F-Mount adapter