

TCCR4M056-C

Telecentric CORE lens for 4/3" detectors, magnification 0.314 x, C-mount

SPECIFICATIONS

Part number	TCCR4M056-C	
Magnification	(x)	0.314
Image shape dimension (8)	(\varnothing , x mm)	$\varnothing=22.0$, x=19.2
Phase adjustment (7)	Yes	

Object field of view 7

with KAI-2020 14.8 mm diagonal w x h 11.84 x 8.88	(mm x mm)	37.7 x 28.3
with KAI-04050 16 mm diagonal w x h 12.8 x 9.6	(mm x mm)	40.8 x 30.6
with KAI-4022/4021 21.5 mm diagonal w x h 15.2 x 15.2	(mm x mm)	48.4 x 48.4
with KAI-08050 22.6 mm diagonal w x h 18.1 x 13.6	(mm x mm)	57.6 x 43.3

Optical specifications

Working distance (1)	(mm)	157.80
wF/# (2)	16	
Telecentricity typical (max) (3)	(deg)	< 0.05 (0.10)
Distortion typical (max) (4)	(%)	< 0.04 (0.10)
Field depth (5)	(mm)	12.0
CTF@ 50 lp/mm	(%)	> 40

Mechanical specifications

Mount (6)	C	
A	(mm)	94
B	(mm)	112
C	(mm)	202
Mass	(g)	1678

Compatibility

LTCLCR056-x, CMHOCR056, CMPTR056, LTCLHP056-x

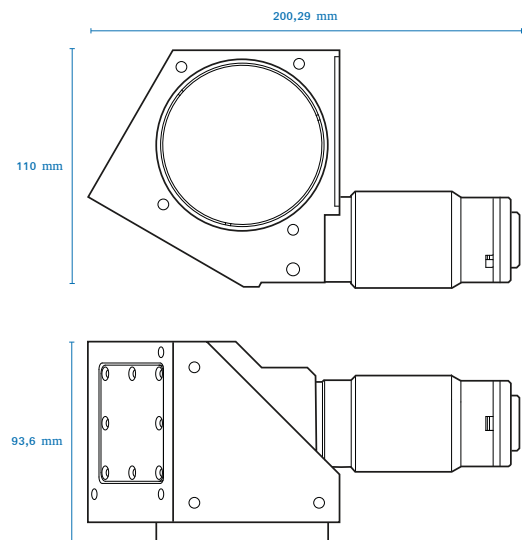
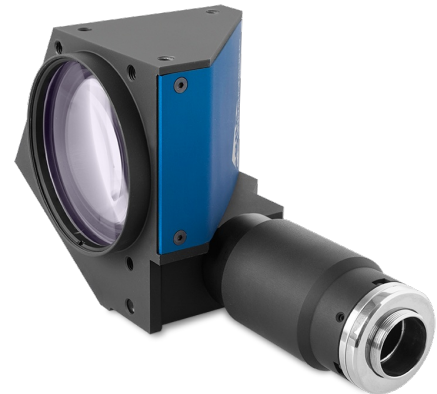

NOTES

- Working distance: distance between the front end of the mechanics and the object. Set this distance within +/- 3% of the nominal value for maximum resolution and minimum distortion.
- Working F-number (wF/#): the real F-number of a lens when used as a macro. Lenses with smaller apertures can be supplied on request.
- Maximum slope of chief rays inside the lens: when converted to milliradians, it gives the maximum measurement error for any millimeter of object displacement. Typical (average production) values and maximum (guaranteed) values are listed.
- Percent deviation of the real image compared to an ideal, undistorted image: typical (average production) values and maximum (guaranteed) values are listed.
- At the borders of the field depth the image can be still used for measurement but, to get a perfectly sharp image, only half of the nominal field depth should be considered. Pixel size used for calculation is 5.5 μm .
- In case the of vignetting, FOV dimensions are indicated with " $\varnothing =$, x =", where " $\varnothing =$ " stands for diameter and "x=" indicates the nominal FOV height and length (see [Tech Info](#) for related drawing).
- Indicates the availability of an integrated camera phase adjustment feature.
- Indicates the dimensions and shape of image, where " $\varnothing =$ " stands for diameter and "x=" indicates the nominal image height and length (see [Tech Info](#) for related drawing)

COMPATIBLE PRODUCTS



LTCLHP056-R	Telecentric HP illuminator, beam diameter 70 mm, red
LTCLHP056-G	Telecentric HP illuminator, beam diameter 70 mm, green
LTCLHP056-B	Telecentric HP illuminator, beam diameter 70 mm, blue
LTCLHP056-W	Telecentric HP illuminator, beam diameter 70 mm, white



LTCLCR056-R Telecentric CORE illuminator, beam dimensions $\varnothing = 74$; x = 66, red

LTCLCR056-G Telecentric CORE illuminator, beam dimensions $\varnothing = 74$; x = 66, green

LTCLCR056-W Telecentric CORE illuminator, beam dimensions $\varnothing = 74$; x = 66, white



CMHOCR056 Clamping mechanics for CORE telecentric lenses and illuminators TCCRxx56 and LTCLCR056-x



CMPTCR056 Mechanical components designed for CORE telecentric lenses and illuminators $\varnothing 56$ mm
