

# TCCR4M048-C

Telecentric CORE lens for 4/3" detectors, magnification 0.369 x, C-mount

## SPECIFICATIONS

Part number	TCCR4M048-C	
Magnification	(x)	0.369
Image shape dimension (8)	( $\varnothing$ , x mm)	$\varnothing=22.1$ , x=18.8
Phase adjustment (7)	Yes	

### Object field of view 7

with KAI-2020 14.8 mm diagonal w x h 11.84 x 8.88	(mm x mm)	32.1 x 24.1
with KAI-04050 16 mm diagonal w x h 12.8 x 9.6	(mm x mm)	34.7 x 26.0
with KAI-4022/4021 21.5 mm diagonal w x h 15.2 x 15.2	(mm x mm)	41.2 x 41.2
with KAI-08050 22.6 mm diagonal w x h 18.1 x 13.6	(mm x mm)	49.1 x 36.9

### Optical specifications

Working distance (1)	(mm)	133.41
wF/# (2)	16	
Telecentricity typical (max) (3)	(deg)	< 0.08 (0.10)
Distortion typical (max) (4)	(%)	< 0.08 (0.10)
Field depth (5)	(mm)	8.7
CTF@ 50 lp/mm	(%)	> 40

### Mechanical specifications

Mount (6)	C	
A	(mm)	77
B	(mm)	109
C	(mm)	193
Mass	(g)	1249

### Compatibility

LTCLCR048-x, CMHOCR048, CMPTCR048, LTCLHP048-x

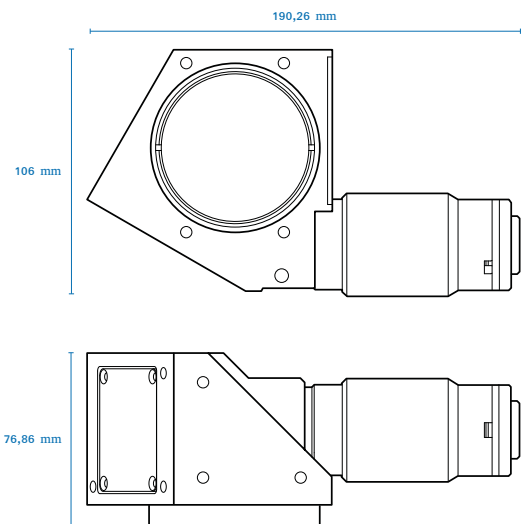

## NOTES

- Working distance: distance between the front end of the mechanics and the object. Set this distance within +/- 3% of the nominal value for maximum resolution and minimum distortion.
- Working F-number (wF/#): the real F-number of a lens when used as a macro. Lenses with smaller apertures can be supplied on request.
- Maximum slope of chief rays inside the lens: when converted to milliradians, it gives the maximum measurement error for any millimeter of object displacement. Typical (average production) values and maximum (guaranteed) values are listed.
- Percent deviation of the real image compared to an ideal, undistorted image: typical (average production) values and maximum (guaranteed) values are listed.
- At the borders of the field depth the image can be still used for measurement but, to get a perfectly sharp image, only half of the nominal field depth should be considered. Pixel size used for calculation is 5.5  $\mu\text{m}$ .
- In case the of vignetting, FOV dimensions are indicated with " $\varnothing =$ , x =", where " $\varnothing =$ " stands for diameter and "x=" indicates the nominal FOV height and length (see [Tech Info](#) for related drawing).
- Indicates the availability of an integrated camera phase adjustment feature.
- Indicates the dimensions and shape of image, where " $\varnothing =$ " stands for diameter and "x=" indicates the nominal image height and length (see [Tech Info](#) for related drawing)

## COMPATIBLE PRODUCTS



<b>LTCLHP048-R</b>	Telecentric HP illuminator, beam diameter 60 mm, red
<b>LTCLHP048-G</b>	Telecentric HP illuminator, beam diameter 60 mm, green
<b>LTCLHP048-B</b>	Telecentric HP illuminator, beam diameter 60 mm, blue
<b>LTCLHP048-W</b>	Telecentric HP illuminator, beam diameter 60 mm, white



---

**LTCLCR048-R** Telecentric CORE illuminator, beam dimensions  $\varnothing = 56$ ;  $x = 50$ , red

---

**LTCLCR048-G** Telecentric CORE illuminator, beam dimensions  $\varnothing = 56$ ;  $x = 50$ , green

---

**LTCLCR048-W** Telecentric CORE illuminator, beam dimensions  $\varnothing = 56$ ;  $x = 50$ , white

---



---

**CMHOCR048** Clamping mechanics for CORE telecentric lenses and illuminators TCCRxx48 and LTCLCR048-x

---



---

**CMPTCR048** Mechanical components designed for CORE telecentric lenses and illuminators  $\varnothing 48\text{mm}$

---