



TCCR23096

Bi-telecentric CORE lens for 2/3" detectors, magnification 0.093 x, C-mount

SPECIFICATIONS

Part number (8)		TCCR23096
Magnification	(x)	0.093
Image shape dimension (9)	(\emptyset , x mm)	$\emptyset=11.4$, x=9.4
Phase adjustment (7)		Yes

Object field of view (6)

with 1/3" detector (4.8 x 3.6 mm)	(mm x mm)	51.4 x 38.5
with 1/2.5" detector (5.70 x 4.28 mm)	(mm x mm)	61.0 x 45.8
with 1/2" detector (6.4 x 4.8 mm)	(mm x mm)	68.5 x 51.4
with 1/1.8" detector (7.13 x 5.37 mm)	(mm x mm)	76.3 x 57.5
with 2/3" - 5 MP detector (8.45 x 7.07 mm)	(mm x mm)	90.4 x 75.6

Optical specifications

Working distance (1)	(mm)	278.6
wF/# (2)		8
Telecentricity typical (max) (3)	(deg)	< 0.06 (0.08)
Distortion typical (max) (4)	(%)	< 0.04 (0.10)
Field depth (5)	(mm)	77
CTF @ 70 lp/mm	(%)	> 40

Dimensions

Mount		C
A	(mm)	139
B	(mm)	172
C	(mm)	197
Mass	(g)	4269

Compatibility

LTCLCR096-x, CMHOCR096, CMPTR096, LTCLHP096-x

NOTES

- Working distance: distance between the front end of the mechanics and the object. Set this distance within +/- 3% of the nominal value for maximum resolution and minimum distortion.
- Working F-number (wF/#): the real F-number of a lens when used as a macro. Lenses with smaller apertures can be supplied on request.
- Maximum slope of chief rays inside the lens: when converted to millirad, it gives the maximum measurement error for any millimeter of object displacement. Typical (average production) values and maximum (guaranteed) values are listed.
- Percent deviation of the real image compared to an ideal, undistorted image: typical (average production) values and maximum (guaranteed) values are listed.
- At the borders of the field depth the image can be still used for measurement but, to get a perfectly sharp image, only half of the nominal field depth should be considered. Pixel size used for calculation is 5.5 μ m.
- In case the of vignetting, FOV dimensions are indicated with " $\emptyset =$, x = ", where " $\emptyset =$ " stands for diameter and "x=" indicates the nominal FOV height and length (see [Tech Info](#) for related drawing).
- Indicates the availability of an integrated camera phase adjustment feature.
- Due to the special shape of TCCR120xx it might be necessary to check the mechanical compatibility with your camera.
- Indicates the dimensions and shape of image, where " $\emptyset =$ " stands for diameter and "x=" indicates the nominal image height and length ([Tech Info](#) for related drawing).

COMPATIBLE PRODUCTS



LTCLHP096-G	Telecentric HP illuminator, beam diameter 120 mm, green
LTCLHP096-R	Telecentric HP illuminator, beam diameter 120 mm, red

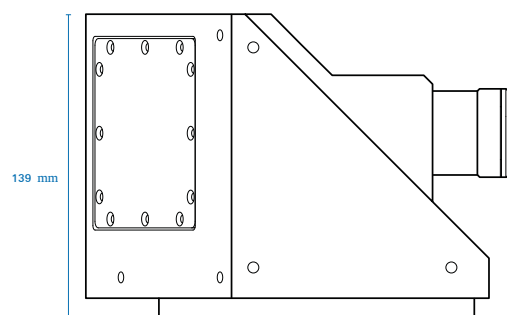
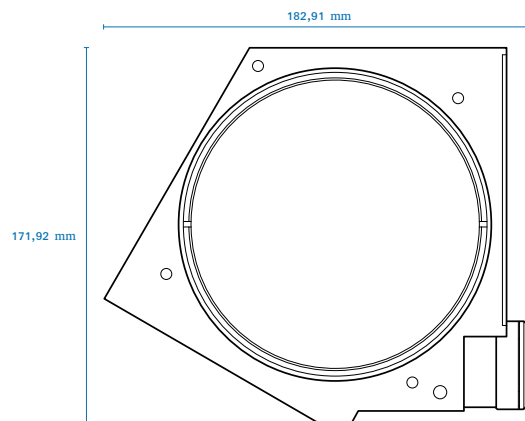

LTCLHP096-B	Telecentric HP illuminator, beam diameter 120 mm, blue
LTCLHP096-W	Telecentric HP illuminator, beam diameter 120 mm, white



LTCLCR096-R	Telecentric CORE illuminator, beam dimensions $\varnothing = 120$; $x = 99$, red
LTCLCR096-G	Telecentric CORE illuminator, beam dimensions $\varnothing = 120$; $x = 99$, green
LTCLCR096-W	Telecentric CORE illuminator, beam dimensions $\varnothing = 120$; $x = 99$, white



CMHOCR096	Clamping mechanics for CORE telecentric lenses and illuminators TCCRxx96 and LTCLCR096-x
------------------	--



CMPTCR096	Mechanical components designed for CORE telecentric lenses and illuminators $\varnothing 96$ mm
------------------	---
