

ON Semiconductor®

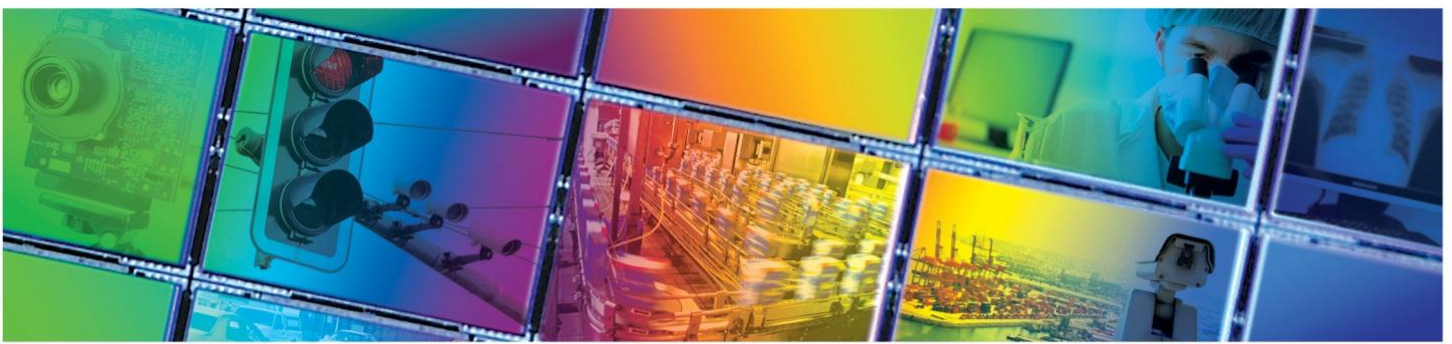

KAI-0340 IMAGE SENSOR

640 (H) X 480 (V) INTERLINE CCD IMAGE SENSOR



JULY 11, 2014

DEVICE PERFORMANCE SPECIFICATION

REVISION 1.1 PS-0024



TABLE OF CONTENTS

Summary Specification	5
Description	5
Features	5
Applications	5
Ordering Information	6
Device Description	7
Architecture	7
ESD Protection	8
Pin Description and Physical Orientation	9
Imaging Performance	10
Imaging Performance Operational Conditions	10
Imaging Performance Specifications	10
All Configurations	10
Monochrome Configurations	11
Color Configurations	11
Typical Performance Curves	12
Quantum Efficiency.....	12
Monochrome with Microlens.....	12
Monochrome without Microlens	12
Color (Bayer RGB) with Microlens	13
Angular Quantum Efficiency.....	13
Monochrome with Microlens.....	13
Power - Estimated	14
Frame Rates	15
Defect Definitions	16
Monochrome (excluding KAI-0340-ABB-CB-A2-Single)	16
Monochrome (KAI-0340-ABB-CB-A2-Single Only).....	16
Color Versions	16
Defect Map.....	16
Test Definitions	17
Test Regions of Interest	17
Test Sub Regions of Interest	17
OverClocking	17
Tests.....	18
Global Non-Uniformity.....	18
Global Peak to Peak Non-Uniformity.....	18
Center Non-Uniformity	19
Dark Field Defect Test	19
Bright Field Defect Test.....	19
Operation	20
Maximum Ratings	20
Maximum Voltage Ratings Between Pins	20
DC Bias Operating Conditions.....	21
AC Operating Conditions.....	22
Clock Levels	22
Clock Line Capacitances.....	22
Timing Requirements	23
Timing Sequences.....	24



Timing Sequence A: Photodiode to VCCD transfer, Entire Image 24

Timing Sequence B: Vertical CCD Line Shift and Horizontal CCD Readout of One Line 25

Timing Sequence C: Photodiode to VCCD Transfer, Center 164 Rows 26

Timing Sequence D: No Vertical CCD Line Transfer, Readout of One Horizontal CCD Line 27

Timing Modes 28

 Sensor Architecture 28

 One Output Full Field 29

 Two Outputs Full Field 30

 One Output Center Columns 31

 Two Outputs Center Columns 32

 One Output Center Rows 33

 Two Outputs Center Rows 34

 One Output Center Rows and Columns 35

 Two Outputs Center Rows and Columns 36

Timing Details 37

 Pixel Timing 37

 Vertical Clock Phase 1 – Line Timing Detail 38

 Vertical Clock Phase 2 – Line Timing Detail 39

 Vertical Clocks Phases 1 and 2 – Line Timing Detail 40

 Vertical Clock Phase 1 – Frame Timing Detail 41

 Vertical Clock Phase 2 – Frame Timing Detail 42

 Vertical Clocks Phases 1 and 2 – Frame Timing Detail 43

 Electronic Shutter Timing 44

 Electronic Shutter – Integration Time Definition 45

 Fast Line Dump Timing 46

Example HCCD Clock Driver 47

 Single Output Only 47

 Selectable Single or Dual Output 47

 Dual Output Only 47

Storage and Handling 48

 Storage Conditions 48

 ESD 48

 Cover Glass Care and Cleanliness 48

 Environmental Exposure 48

 Soldering Recommendations 48

Mechanical Drawings 49

 Completed Assembly 49

 Die to Package Alignment 50

 Glass 51

 Clear Cover Glass 51

 Quartz Cover Glass 52

 Glass Transmission 53

 Clear Cover Glass 53

 Quartz Cover Glass 53

Quality Assurance and Reliability 54

 Quality and Reliability 54

 Replacement 54

 Liability of the Supplier 54

 Liability of the Customer 54

 Test Data Retention 54

 Mechanical 54



Life Support Applications Policy54

Revision Changes.....55

MTD/PS-0714..... 55

PS-0024 55

TABLE OF FIGURES

Figure 1: Sensor Architecture 7

Figure 2: ESD Protection 8

Figure 3: Package Pin Designations - Top View..... 9

Figure 4: Monochrome with Microlens Quantum Efficiency..... 12

Figure 5: Monochrome without Microlens Quantum Efficiency..... 12

Figure 6: Color with Microlens Quantum Efficiency..... 13

Figure 7: Angular Quantum Efficiency..... 13

Figure 8: Power 14

Figure 9: Frame Rates 15

Figure 10: Test Sub Regions of Interest 17

Figure 11: Overclock Regions of Interest 17

Figure 12: Output Amplifier 21

Figure 13: Timing Sequence A 24

Figure 14: Timing Sequence B 25

Figure 15: Timing Sequence C 26

Figure 16: Timing Sequence D 27

Figure 17: Pixel Timing Detail 37

Figure 18: Electronic Shutter Timing 44

Figure 19: Integration Time Definition..... 45

Figure 20: Fast Line Dump Timing 46

Figure 21: Completed Assembly 49

Figure 22: Die to Package Alignment 50

Figure 23: Glass Drawing..... 51

Figure 24: Quartz Cover Glass 52

Figure 25: Clear Cover Glass Transmission 53

Figure 26: Quartz Cover Glass Transmission..... 53



Summary Specification

KAI-0340 Image Sensor

DESCRIPTION

The KAI-0340 image sensor is a 640 (H) x 480 (V) resolution, 1/3" optical format, progressive scan interline CCD. This image sensor is offered in 2 versions: the KAI-0340-Dual supports 210 full resolution frame-per-second readout while the KAI-0340-Single supports 110 frame-per-second readout. Frame rates as high as 2,000 Hz (KAI-0340-Single) and 3,400 Hz (KAI-0340-Dual) can be achieved by combining the Fast Horizontal Line Dump with custom clocking modes. Designed for demanding imaging applications, the KAI-0340 provides electronic shuttering, peak QE (quantum efficiency) of 55%, extremely low noise and low dark current. These features give this sensor exceptional sensitivity and make it ideal for machine vision, scientific, surveillance, and other computer input applications.

FEATURES

- High sensitivity
- High dynamic range
- Low noise architecture
- High frame rate
- Electronic shutter

APPLICATIONS

- Intelligent Transportation Systems
- Machine Vision
- Scientific

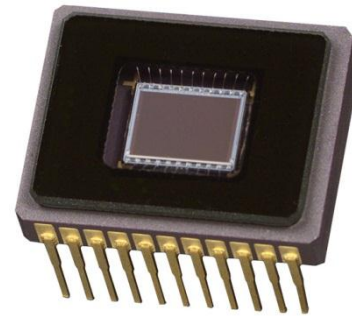

Parameter	Value
Architecture	Interline CCD; Progressive Scan
Total Number of Pixels	696 (H) x 492 (V)
Number of Effective Pixels	648 (H) x 484 (V)
Number of Active Pixels	640 (H) x 480 (V)
Pixel Size	7.4 μm (H) x 7.4 μm (V)
Active Image Size	4.736mm (H) x 3.552mm (V) 5.920mm (diagonal) 1/3" optical format
Aspect Ratio	4:3
Number of Outputs	1 or 2
Charge Capacity	40 MHz – 20,000 electrons 20 MHz – 40,000 electrons
Output Sensitivity	30 $\mu\text{V}/\text{e}$
Photometric Sensitivity KAI-0340-ABB	3.61 V/lux-sec
Photometric Sensitivity KAI-0340-CBA	1.17(B), 1.54(G), 0.65(R) V/lux-sec
Readout Noise	40 MHz – 16 electrons 20 MHz – 14 electrons
Dynamic Range	40 MHz – 62 dB 20 MHz – 69 dB
Dark Current	Photodiode < 200 eps VCCD < 1000 eps
Maximum Pixel Clock Speed	40MHz
Maximum Frame Rate	KAI-0340-Dual – 210 fps KAI-0340-Single – 110 fps
Package Type	CerDIP
Package Size	0.500" [12.70mm] width 0.625" [15.87mm] length
Package Pins	22
Package Pin Spacing	0.050"

All parameters above are specified at T = 40 °C



Ordering Information

Catalog Number	Product Name	Description	Marking Code
4H0655	KAI-0340-AAA-CP-AA-Single	Monochrome, No Microlens, CERDIP Package (sidebrazed), Taped Clear Cover Glass, no coatings, Standard Grade, Single Output	KAI-0340S
4H0656	KAI-0340-AAA-CP-AE-Single	Monochrome, No Microlens, CERDIP Package (sidebrazed), Taped Clear Cover Glass, no coatings, Engineering Grade, Single Output	
4H0657	KAI-0340-AAA-CP-AA-Dual	Monochrome, No Microlens, CERDIP Package (sidebrazed), Taped Clear Cover Glass, no coatings, Standard Grade, Dual Output	KAI-0340D
4H0658	KAI-0340-AAA-CP-AE-Dual	Monochrome, No Microlens, CERDIP Package (sidebrazed), Taped Clear Cover Glass, no coatings, Engineering Grade, Dual Output	
4H0659	KAI-0340-AAA-CF-AA-Single	Monochrome, No Microlens, CERDIP Package (sidebrazed), Quartz Cover Glass, no coatings, Standard Grade, Single Output	KAI-0340S
4H0660	KAI-0340-AAA-CF-AE-Single	Monochrome, No Microlens, CERDIP Package (sidebrazed), Quartz Cover Glass, no coatings, Engineering Grade, Single Output	
4H0661	KAI-0340-AAA-CF-AA-Dual	Monochrome, No Microlens, CERDIP Package (sidebrazed), Quartz Cover Glass, no coatings, Standard Grade, Dual Output	KAI-0340D
4H0662	KAI-0340-AAA-CF-AE-Dual	Monochrome, No Microlens, CERDIP Package (sidebrazed), Quartz Cover Glass, no coatings, Engineering Grade, Dual Output	
4H0872	KAI-0340-ABB-CP-AA-Single	Monochrome, Telecentric Microlens, CERDIP Package (sidebrazed), Taped Clear Cover Glass, no coatings, Standard Grade, Single Output	KAI-0340ABBS
4H0873	KAI-0340-ABB-CP-AE-Single	Monochrome, Telecentric Microlens, CERDIP Package (sidebrazed), Taped Clear Cover Glass, no coatings, Engineering Grade, Single Output	
4H0874	KAI-0340-ABB-CP-AA-Dual	Monochrome, Telecentric Microlens, CERDIP Package (sidebrazed), Taped Clear Cover Glass, no coatings, Standard Grade, Dual Output	KAI-0340ABBD
4H0875	KAI-0340-ABB-CP-AE-Dual	Monochrome, Telecentric Microlens, CERDIP Package (sidebrazed), Taped Clear Cover Glass, no coatings, Engineering Grade, Dual Output	
4H0868	KAI-0340-ABB-CB-AA-Single	Monochrome, Telecentric Microlens, CERDIP Package (sidebrazed), Clear Cover Glass, no coatings, Standard Grade, Single Output	KAI-0340ABBS
4H2143	KAI-0340-ABB-CB-A2-Single	Monochrome, Telecentric Microlens, CERDIP Package (sidebrazed), Clear Cover Glass, no coatings, Grade 2, Single Output	
4H0869	KAI-0340-ABB-CB-AE-Single	Monochrome, Telecentric Microlens, CERDIP Package (sidebrazed), Clear Cover Glass, no coatings, Engineering Grade, Single Output	
4H0870	KAI-0340-ABB-CB-AA-Dual	Monochrome, Telecentric Microlens, CERDIP Package (sidebrazed), Clear Cover Glass, no coatings, Standard Grade, Dual Output	KAI-0340ABBD
4H0871	KAI-0340-ABB-CB-AE-Dual	Monochrome, Telecentric Microlens, CERDIP Package (sidebrazed), Clear Cover Glass, no coatings, Engineering Grade, Dual Output	
4H0663	KAI-0340-CBA-CB-AA-Single	Color (Bayer RGB), Telecentric Microlens, CERDIP Package (sidebrazed), Clear Cover Glass, no coatings, Standard Grade, Single Output	KAI-0340SCM
4H0664	KAI-0340-CBA-CB-AE-Single	Color (Bayer RGB), Telecentric Microlens, CERDIP Package (sidebrazed), Clear Cover Glass, no coatings, Engineering Grade, Single Output	
4H0665	KAI-0340-CBA-CB-AA-Dual	Color (Bayer RGB), Telecentric Microlens, CERDIP Package (sidebrazed), Clear Cover Glass, no coatings, Standard Grade, Dual Output	KAI-0340DCM
4H0666	KAI-0340-CBA-CB-AE-Dual	Color (Bayer RGB), Telecentric Microlens, CERDIP Package (sidebrazed), Clear Cover Glass, no coatings, Engineering Grade, Dual Output	
4H0472	KEK-4H0472-KAI-0340-10-40	Evaluation Board (Complete Kit)	n/a

See Application Note *Product Naming Convention* for a full description of the naming convention used for image sensors. For reference documentation, including information on evaluation kits, please visit our web site at www.truesenseimaging.com.

Please address all inquiries and purchase orders to:

Truesense Imaging, Inc.
1964 Lake Avenue
Rochester, New York 14615

Phone: (585) 784-5500
E-mail: info@truesenseimaging.com

ON Semiconductor reserves the right to change any information contained herein without notice. All information furnished by ON Semiconductor is believed to be accurate.



Device Description

ARCHITECTURE

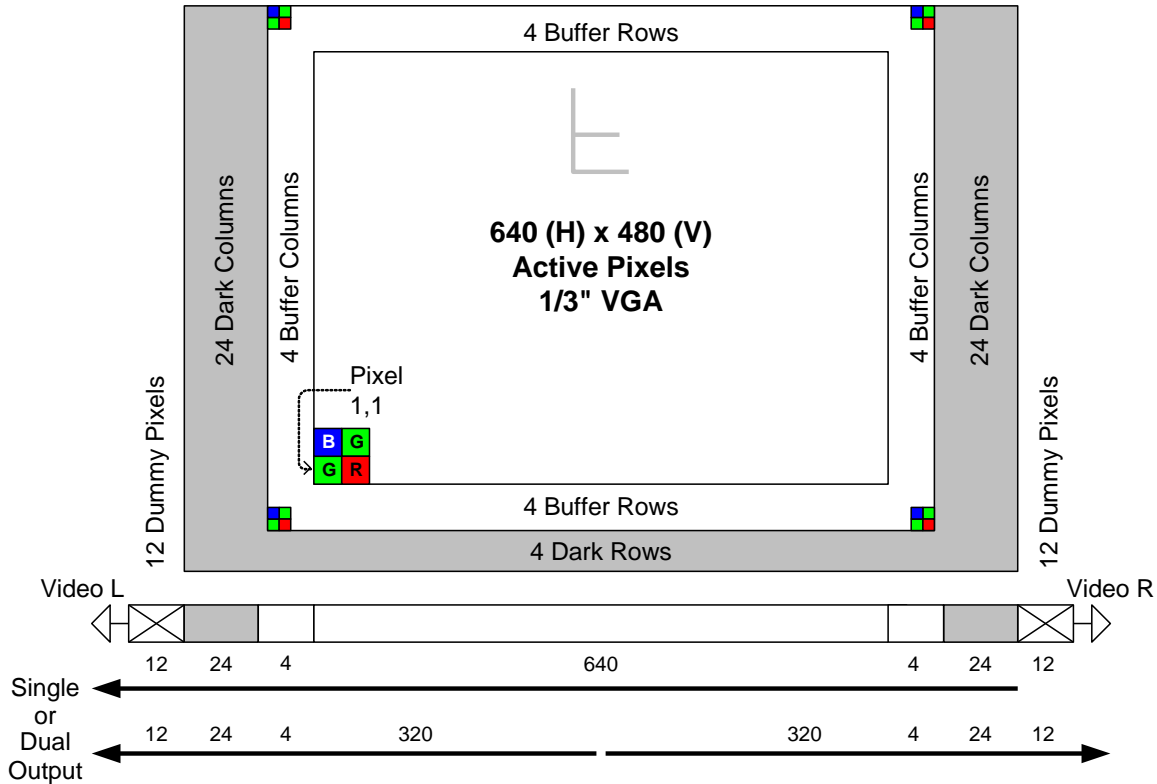

Figure 1: Sensor Architecture

There are 4 light-shielded rows followed by 488 photoactive rows. The first 4 and the last 4 photoactive rows are buffer rows giving a total of 480 lines of image data.

In the single output mode all pixels are clocked out of the Video L output in the lower left corner of the sensor. The first 12 empty pixels of each line do not receive charge from the vertical shift register. The next 24 pixels receive charge from the left light-shielded edge followed by 648 photosensitive pixels and finally 24 more light-shielded pixels from the right edge of the sensor. The first and last 4 photosensitive pixels are buffer pixels giving a total of 640 pixels of image data.

In the dual output mode the clocking of the right half of the horizontal CCD is reversed. The left half of the image is clocked out Video L and the right half of the image is clocked out Video R. Each row consists of 12 empty pixels followed by 24 light-shielded pixels followed by 324 photosensitive pixels. When reconstructing the image, data from Video R will have to be reversed in a line buffer and appended to the Video L data.

There are no dark reference rows at the top and 4 dark rows at the bottom of the image sensor. The 4 dark rows are not entirely dark and so should not be used for a dark reference level. Use the 24 dark columns on the left or right side of the image sensor as a dark reference.

Of the 24 dark columns, the first and last dark columns should not be used for determining the zero signal level. Some light does leak into the first and last dark columns. Only use the center 22 columns of the 24 column dark reference.



ESD PROTECTION

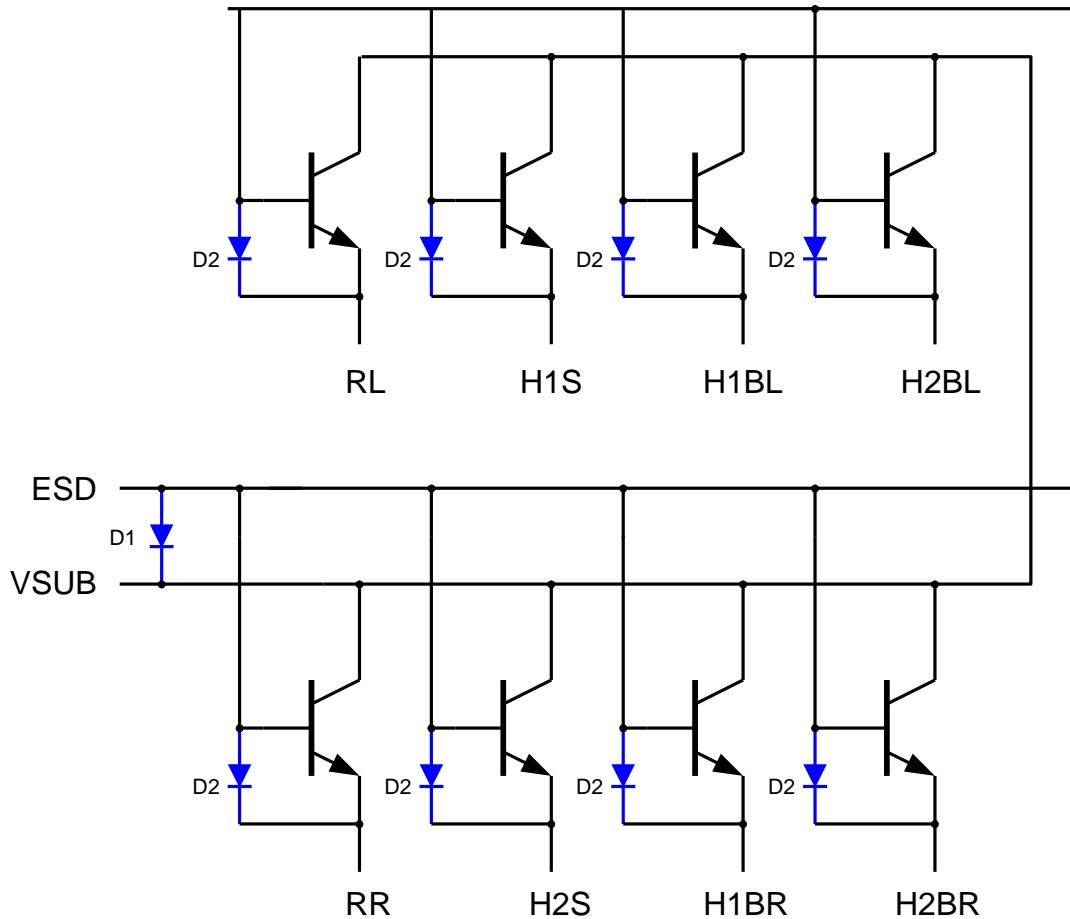

Figure 2: ESD Protection

The ESD protection on the KAI-0340 is implemented using bipolar transistors. The substrate (SUB) forms the common collector of all the ESD protection transistors. The ESD pin is the common base of all the ESD protection transistors. Each protected pin is connected to a separate emitter as shown in Figure 2.

The ESD circuit turns on if the base-emitter junction voltage exceeds 17 V. Care must be taken while operating the image sensor, especially during the power on sequence, to not forward bias the base-emitter or base-collector junctions. If it is possible for the camera power up sequence to forward bias these junctions then diodes D1 and D2 should be added to protect the image sensor. Put one diode D1 between the ESD and VSUB pins. Put one diode D2 on each pin that may forward bias the base-emitter junction. The diodes will prevent large currents from flowing through the image sensor. Note that external diodes D1 and D2 are optional and are only needed if it is possible to forward bias any of the junctions.

Note that diodes D1 and D2 are added external to the KAI-0340.



PIN DESCRIPTION AND PHYSICAL ORIENTATION

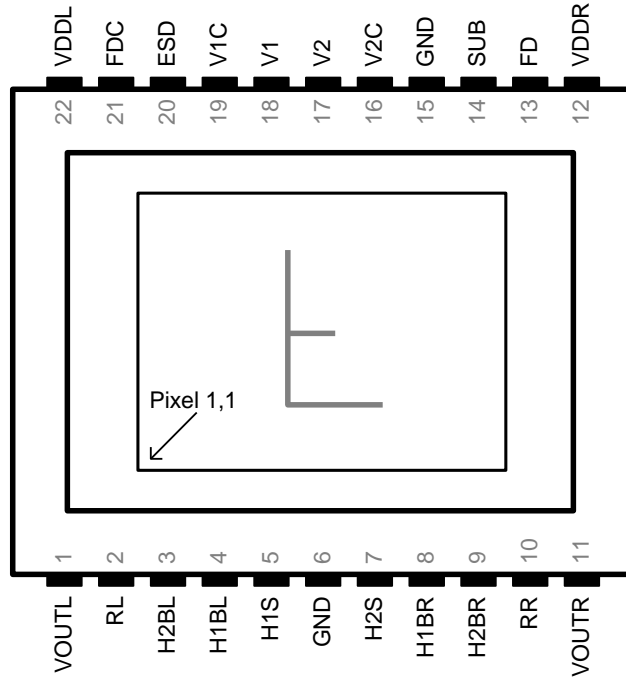

Figure 3: Package Pin Designations - Top View

Pin	Name	Description
1	VOUTL	Video Output, Left
2	RL	Reset Gate, Left
3	H2BL	Horizontal Clock, Phase 2, Barrier, Left
4	H1BL	Horizontal Clock, Phase 1, Barrier, Right
5	H1S	Horizontal Clock, Phase 1, Storage
6	GND	Ground
7	H2S	Horizontal Clock, Phase 2, Storage
8	H1BR	Horizontal Clock, Phase 1, Barrier, Right
9	H2BR	Horizontal Clock, Phase 2, Barrier, Right
10	RR	Reset Gate, Right
11	VOUTR	Video Output, Right

Pin	Name	Description
22	VDDL	Vdd, Left
21	FDC	Fast Line Dump Gate, Center Columns
20	ESD	ESD
19	V1C	Vertical Clock, Phase 1, Center Rows
18	V1	Vertical Clock, Phase 1, Top and Bottom Rows
17	V2	Vertical Clock, Phase 2, Top and Bottom Rows
16	V2C	Vertical Clock, Phase 2, Center Rows
15	GND	Ground
14	SUB	Substrate
13	FD	Fast Line Dump Gate, Left and Right Columns
12	VDDR	Vdd, Right

Notes:

1. The pins are on a 0.050" spacing
2. If the vertical windowing option is not to be used, then the V1 and V1C pins should be driven from one clock driver. The V2 and V2C pins should also be driven from one clock driver.
3. If the fast dump windowing option is not to be used, then the FD and FDC pins should be driven from the same clock driver.
4. The VOUTR pin is not enabled in the KAI-0340-Single version.



Imaging Performance

IMAGING PERFORMANCE OPERATIONAL CONDITIONS

Unless otherwise noted, Imaging Performance Specifications are measured using the following conditions.

Description	Condition	Notes
Frame Time	53 msec	1
Horizontal Clock Frequency	10 MHz	
Light Source	Continuous red, green and blue illumination centered at 450, 530 and 650 nm	2,3
Operation	Nominal operating voltages and timing	

Notes:

1. Electronic shutter is not used. Integration time equals frame time.
2. LEDs used: Blue: Nichia NLPB500, Green: Nichia NSPG500S and Red: HP HLMP-8115.
3. For monochrome sensor, only green LED used.

IMAGING PERFORMANCE SPECIFICATIONS

All Configurations

Description	Symbol	Min.	Nom.	Max.	Units	Sampling Plan	Temperature Tested At (°C)	Notes	Test
Photodiode CCD Dark Current	I _{pd}	0	40	200	e/p/s	Die	27, 40		
Vertical CCD Dark Current	I _{vd}	0	400	1000	e/p/s	Die	27, 40		
Dark Current Doubling Temperature		n/a	7	n/a	°C	Design			
Horizontal CCD Charge Capacity	HNe	80	n/a	n/a	ke ⁻	Design			
Vertical CCD Charge Capacity	VNe	50	n/a	n/a	ke ⁻	Design			
Horizontal CCD Charge Transfer Efficiency	HCTE	0.99999	n/a	n/a		Design			
Vertical CCD Charge Transfer Efficiency	VCTE	0.99999	n/a	n/a		Design			
Image Lag	Lag	0	<10	50	e ⁻	Design			
Antiblooming Factor	X _{ab}	100	300	n/a		Design			
Vertical Smear	Smr	n/a	80	75	dB	Design			
Output Amplifier DC Offset	V _{odc}	6	n/a	12	V	Die		1	
Output Amplifier Impedance	R _{out}	100	150	200	Ohms	Die		2	
Output Amplifier Bandwidth	F-3db	n/a	140	n/a	MHz	Design			
Output Amplifier Sensitivity	ΔV/ΔN	n/a	30	n/a	μV/e	Design			



Monochrome Configurations

Description	Symbol	Min.	Nom.	Max.	Units	Sampling Plan	Temperature Tested At (°C)	Notes	Test
Global Uniformity		0.0	1.5	3.0	%rms	Die	27, 40		0
Global Peak to Peak Uniformity	PRNU	0.0	5.0	10.0	%pp	Die	27, 40		0
Center Uniformity		0.0	0.6	1.0	%rms	Die	27, 40		0
Photometric Sensitivity KAI-0340M		n/a	3.61	n/a	V/lux-sec	Design		4	

Color Configurations

Description	Symbol	Min.	Nom.	Max.	Units	Sampling Plan	Temperature Tested At (°C)	Notes	Test
Global Uniformity		0.0	2.0	5.0	%rms	Die	27, 40	3	0
Global Peak to Peak Uniformity	PRNU	0.0	5.0	10.0	%pp	Die	27, 40	3	0
Center Uniformity		0.0	1.0	2.0	%rms	Die	27, 40	3	0
Photometric Sensitivity Blue (B) Pixels		n/a	1.17	n/a	V/lux-sec	Design		4	
Photometric Sensitivity Green (G) Pixels		n/a	1.54	n/a	V/lux-sec	Design		4	
Photometric Sensitivity Red (R) Pixels		n/a	0.65	n/a	V/lux-sec	Design		4	

n/a: not applicable

Notes:

1. Measured at sensor output with constant current load of $I_{out} = -5$ mA and during the floating diffusion reset interval (R high).
2. Last stage only. $C_{LOAD} = 10$ pF. Then $F_{-3dB} = (1 / (2\pi * R_{out} * C_{LOAD}))$.
3. Per color.
4. Calculated using quantum efficiency, output amplifier sensitivity, 3200K Plankian source and a CM500S IR-cut filter.



Typical Performance Curves

QUANTUM EFFICIENCY

Monochrome with Microlens

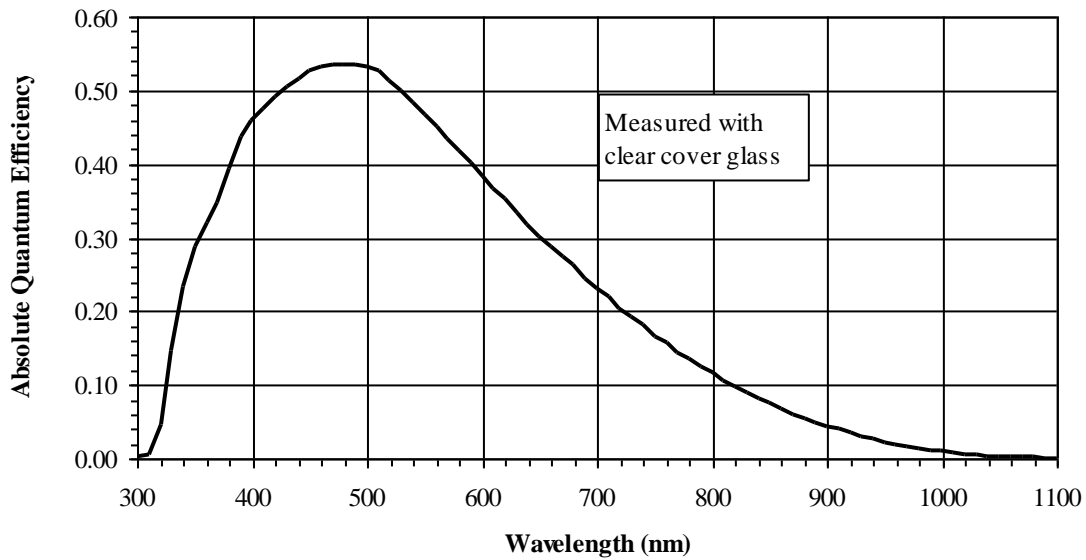

Figure 4: Monochrome with Microlens Quantum Efficiency

Monochrome without Microlens

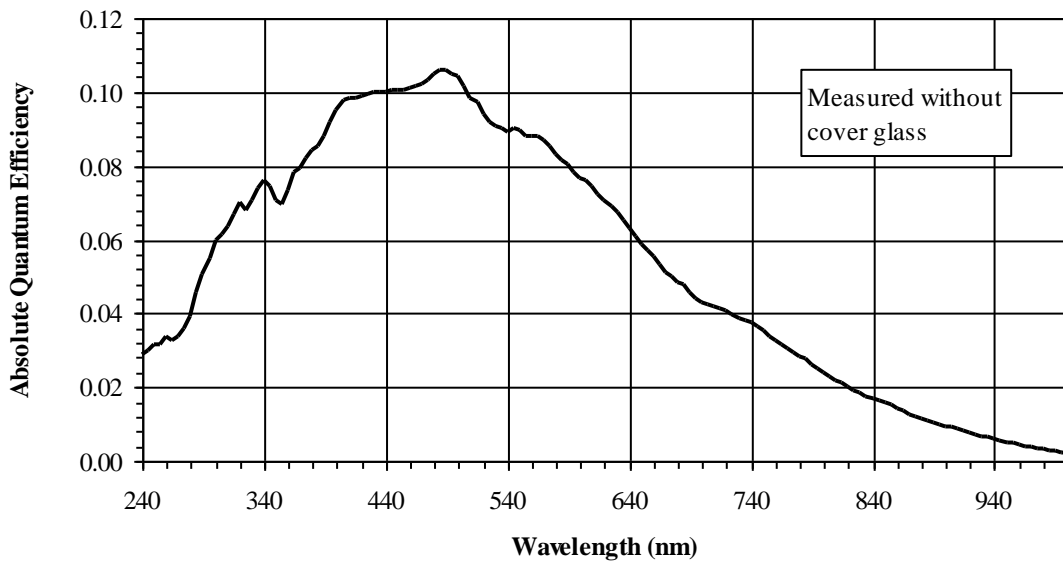

Figure 5: Monochrome without Microlens Quantum Efficiency



Color (Bayer RGB) with Microlens

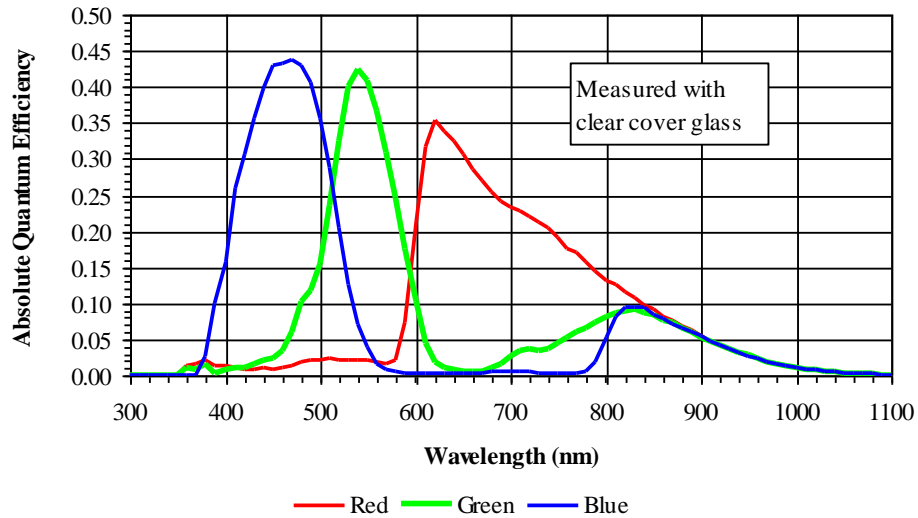

Figure 6: Color with Microlens Quantum Efficiency

ANGULAR QUANTUM EFFICIENCY

Monochrome with Microlens

For the curves marked "Horizontal", the incident light angle is varied in a plane parallel to the HCCD.

For the curves marked "Vertical", the incident light angle is varied in a plane parallel to the VCCD.

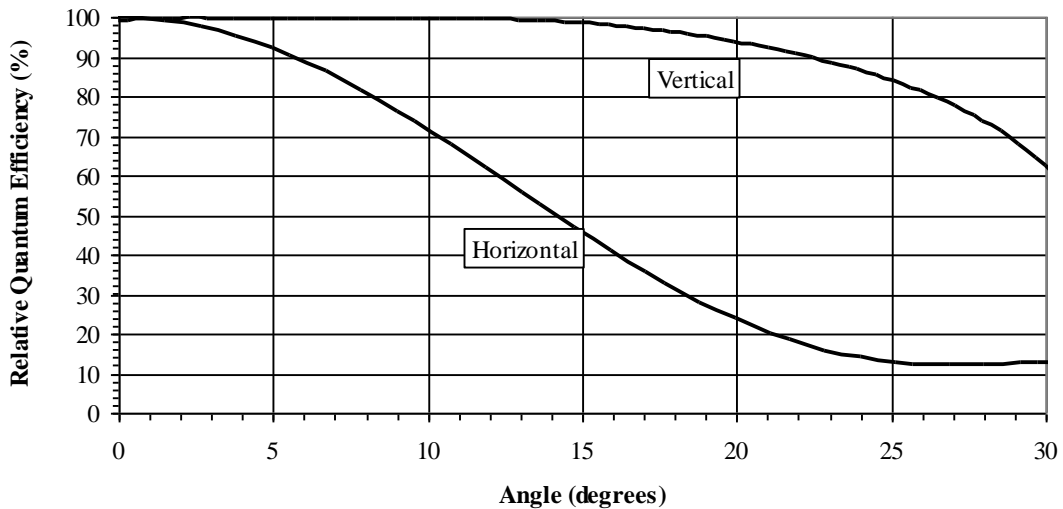

Figure 7: Angular Quantum Efficiency



POWER - ESTIMATED

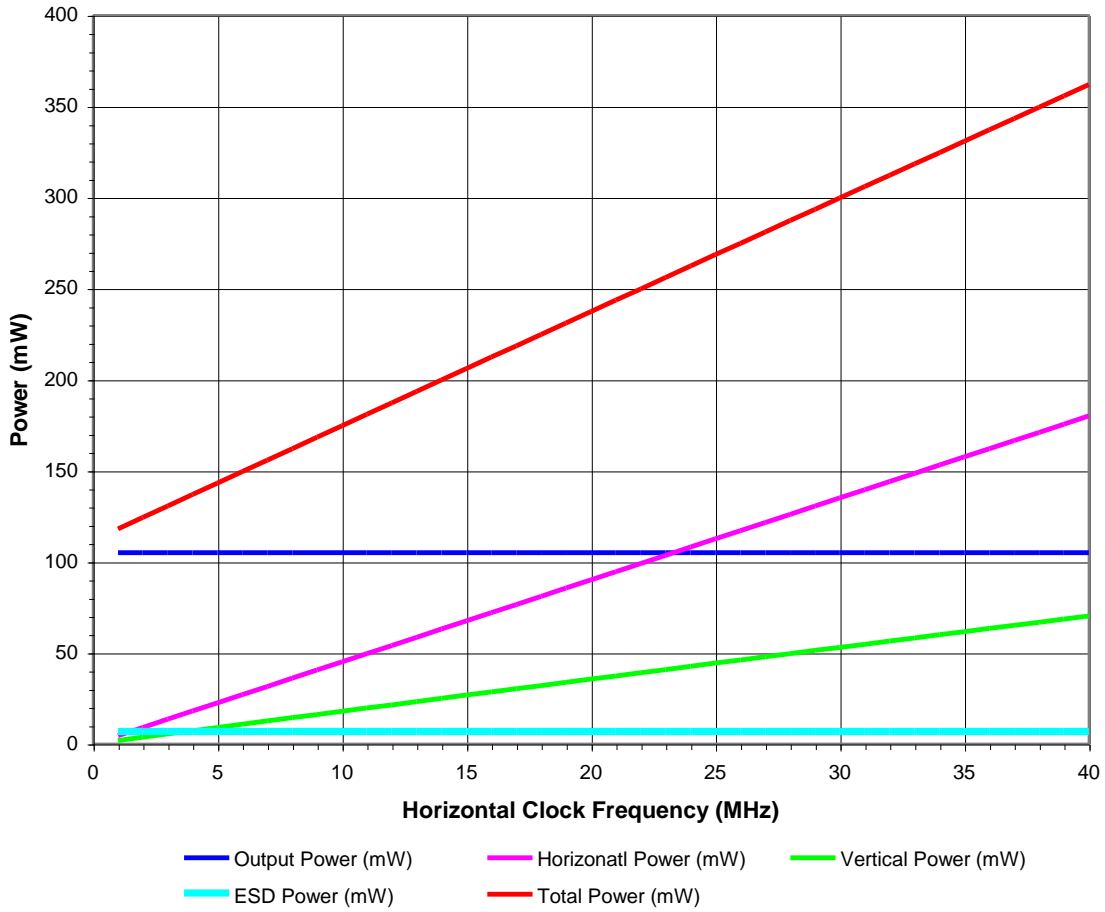

Figure 8: Power



FRAME RATES

Frames rates are for continuous mode operation.

Description	KAI-0340-Single and KAI-0340-Dual Single Output (fps)	KAI-0340-Dual Only Dual Output (fps)
640 x 480	112	214
228 x 480	306	581
640 x 164	325	618
228 x 164	877	1637
228 x 55	2000	3400

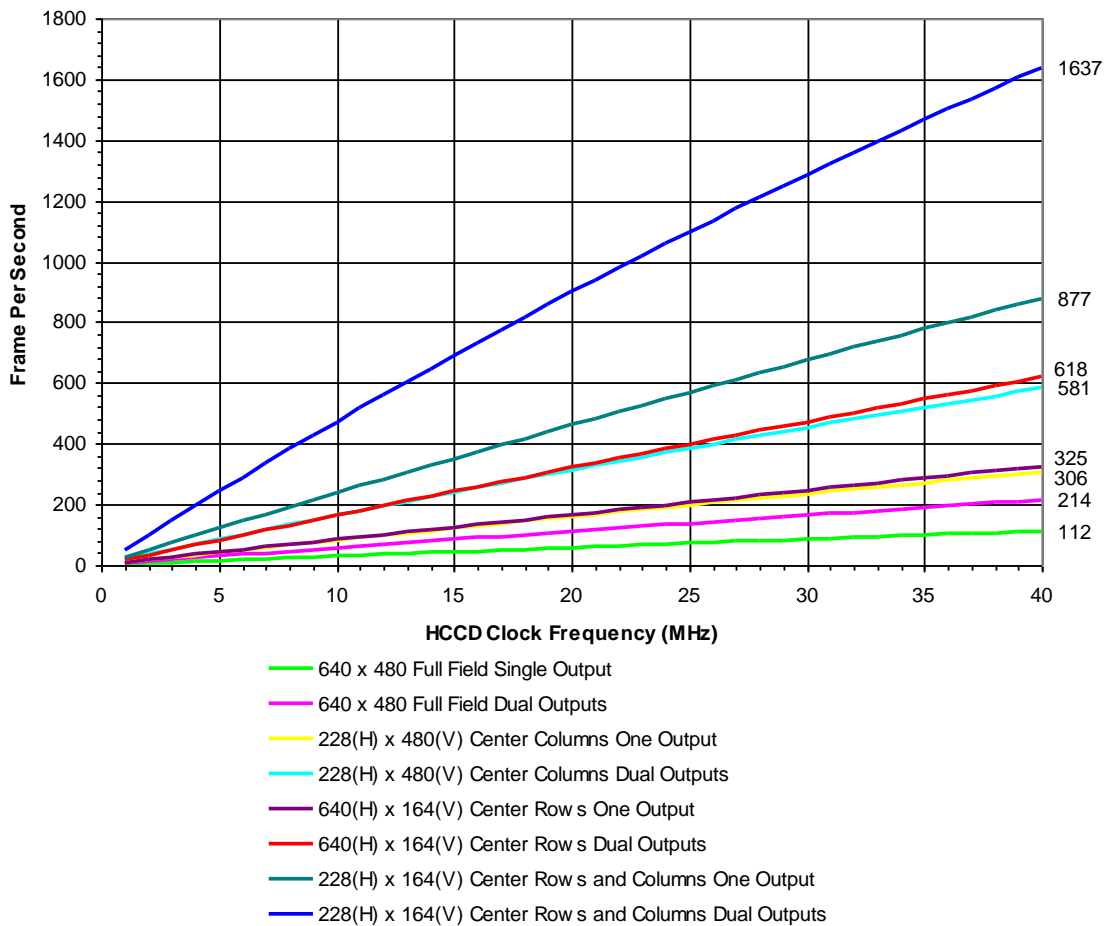

Figure 9: Frame Rates



Defect Definitions

MONOCHROME (EXCLUDING KAI-0340-ABB-CB-A2-SINGLE)

Description	Definition	Maximum	Temperature(s) tested at (°C)	Notes
Major dark field defective pixel	Defect \geq 16mV	2	27, 40	
Major bright field defective pixel	Defect \geq 11%	0	27, 40	
Minor dark field defective pixel	Defect \geq 4mV	100	27, 40	
Dead pixel	Defect \geq 80%	0	27, 40	
Saturated pixel	Defect \geq 30mV	0	27, 40	
Cluster defect	A group of 2 to 10 contiguous major defective pixels	0	27, 40	
Column defect	A group of more than 10 contiguous major defective pixels along a single column	0	27, 40	

MONOCHROME (KAI-0340-ABB-CB-A2-SINGLE ONLY)

Description	Definition	Maximum	Temperature(s) tested at (°C)	Notes
Major dark field defective pixel	Defect \geq 16mV	2	27, 40	
Major bright field defective pixel	Defect \geq 11%	10	27, 40	
Minor dark field defective pixel	Defect \geq 4mV	100	27, 40	
Dead pixel	Defect \geq 80%	0	27, 40	
Saturated pixel	Defect \geq 30mV	0	27, 40	
Cluster defect	A group of 2 to 10 contiguous major defective pixels	0	27, 40	
Column defect	A group of more than 10 contiguous major defective pixels along a single column	0	27, 40	

COLOR VERSIONS

Description	Definition	Maximum	Temperature(s) tested at (°C)	Notes
Major dark field defective pixel	Defect \geq 16mV	2	27, 40	
Major bright field defective pixel	Defect \geq 11%	2	27, 40	
Minor dark field defective pixel	Defect \geq 4mV	100	27, 40	
Dead pixel	Defect \geq 80%	0	27, 40	
Saturated pixel	Defect \geq 30mV	0	27, 40	
Cluster defect	A group of 2 to 10 contiguous major defective pixels	0	27, 40	
Column defect	A group of more than 10 contiguous major defective pixels along a single column	0	27, 40	

DEFECT MAP

No defect maps are available for the KAI-0340 image sensor.



Test Definitions

TEST REGIONS OF INTEREST

Active Area ROI: Pixel (1, 1) to Pixel (640, 480)

Center 100 by 100 ROI: Pixel (270, 190) to Pixel (369, 289)

Only the active pixels are used for performance and defect tests.

TEST SUB REGIONS OF INTEREST

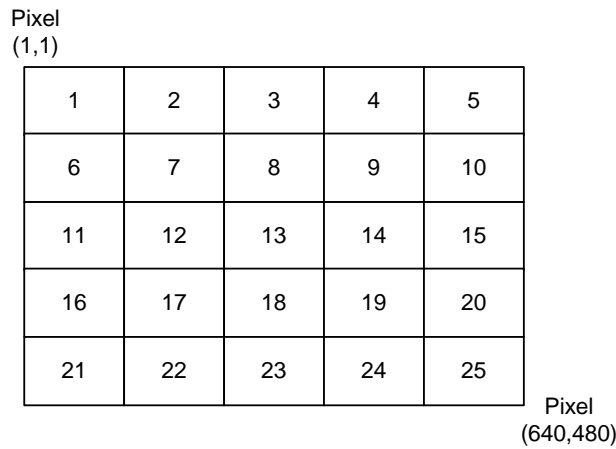

Figure 10: Test Sub Regions of Interest

OVERCLOCKING

The test system timing is configured such that the sensor is overlocked in both the vertical and horizontal directions. See Figure 11 for a pictorial representation of the regions.

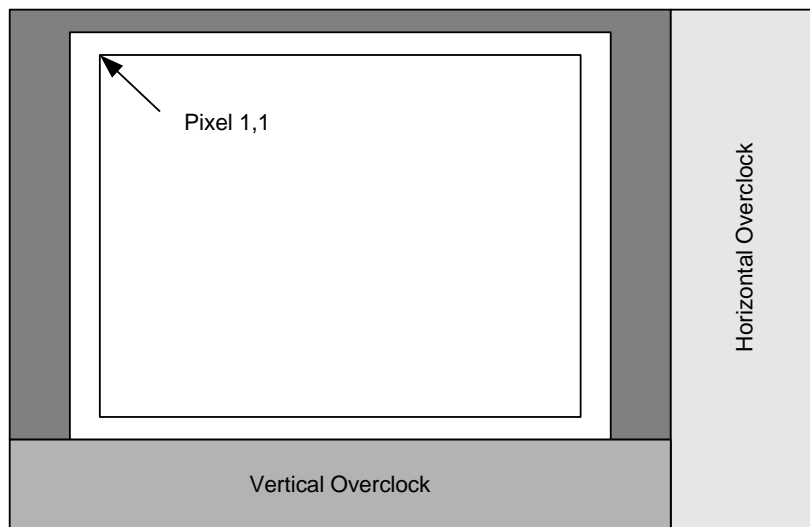

Figure 11: Overclock Regions of Interest



TESTS

Global Non-Uniformity

This test is performed with the imager illuminated to a level such that the output is at 70% of saturation (approximately 420 mV). Prior to this test being performed the substrate voltage has been set such that the charge capacity of the sensor is 600 mV. Global non-uniformity is defined as

$$\text{Global Non - Uniformity} = 100 * \left(\frac{\text{Active Area Standard Deviation}}{\text{Active Area Signal}} \right)$$

Units: %rms. Active Area Signal = Active Area Average – Horizontal Overclock Average

Global Peak to Peak Non-Uniformity

This test is performed with the imager illuminated to a level such that the output is at 70% of saturation (approximately 420 mV). Prior to this test being performed the substrate voltage has been set such that the charge capacity of the sensor is 600 mV. The sensor is partitioned into 25 sub regions of interest, each of which is 128 by 96 pixels in size. The average signal level of each of the 25 sub regions of interest (ROI) is calculated. The signal level of each of the sub regions of interest is calculated using the following formula:

$$A[i] = (\text{ROI Average} - \text{Horizontal Overclock Average})$$

Where i = 1 to 25. During this calculation on the 25 sub regions of interest, the maximum and minimum average signal levels are found. The global peak to peak non-uniformity is then calculated as:

$$\text{Global Non - Uniformity} = 100 * \frac{A[i] \text{ MaximumSignal} - A[i] \text{ MinimumSignal}}{\text{Active Area Signal}}$$

Units: %pp. Active Area Signal = Active Area Average – Horizontal Overclock Average



Center Non-Uniformity

This test is performed with the imager illuminated to a level such that the output is at 70% of saturation (approximately 420 mV). Prior to this test being performed the substrate voltage has been set such that the charge capacity of the sensor is 600 mV. Defects are excluded for the calculation of this test. This test is performed on the center 100 by 100 pixels (See Test Regions of Interest) of the sensor. Center non-uniformity is defined as:

$$\text{Center ROI Non - Uniformity} = 100 * \left(\frac{\text{Center ROI Standard Deviation}}{\text{Center ROI Signal}} \right)$$

Units: %rms. Center ROI Signal = Center ROI Average – Horizontal Overclock Average

Dark Field Defect Test

This test is performed under dark field conditions. The sensor is partitioned into 25 sub regions of interest, each of which is 128 by 96 pixels in size. In each region of interest, the median value of all pixels is found. For each region of interest, a pixel is marked defective if it is greater than or equal to the median value of that region of interest plus the defect threshold specified in “Defect Definitions” section.

Bright Field Defect Test

This test is performed with the imager illuminated to a level such that the output is at 70% of saturation (approximately 420 mV). Prior to this test being performed the substrate voltage has been set such that the charge capacity of the sensor is 600 mV. The average signal level of all active pixels is found. The bright and dark thresholds are set as:

Dark defect threshold = Active Area Signal * threshold

Bright defect threshold = Active Area Signal * threshold

The sensor is then partitioned into 25 sub regions of interest, each of which is 128 by 96 pixels in size. In each region of interest, the average value of all pixels is found. For each region of interest, a pixel is marked defective if it is greater than or equal to the median value of that region of interest plus the bright threshold specified or if it is less than or equal to the median value of that region of interest minus the dark threshold specified.

Example for major bright field defective pixels:

- Average value of all active pixels is found to be 420 mV.
- Dark defect threshold: 420mV * 11% = 46 mV
- Bright defect threshold: 420mV * 11% = 46 mV
- Region of interest #1 selected. This region of interest is pixels 1,1 to pixels 128,96.
 - Median of this region of interest is found to be 420 mV.
 - Any pixel in this region of interest that is $\geq (420+46 \text{ mV})$ 466 mV in intensity will be marked defective.
 - Any pixel in this region of interest that is $\leq (420-46 \text{ mV})$ 374 mV in intensity will be marked defective.
- All remaining 24 sub-regions of interest are analyzed for defective pixels in the same manner.

For the color sensor, the threshold for each color channel is determined independently.



Operation

MAXIMUM RATINGS

Absolute maximum rating is defined as a level or condition that should not be exceeded at any time per the description. If the level or the condition is exceeded, the device will be degraded and may be damaged.

Description	Symbol	Minimum	Maximum	Units	Notes
Operating Temperature	T	-50	70	°C	1
Humidity	RH	5	90	%	2
Output Bias Current	I _{out}	0.0	10	mA	3
Off-chip Load	C _L	n/a	10	pF	4

Notes:

- Noise performance will degrade at higher temperatures.
- T=25 °C. Excessive humidity will degrade MTTF.
- Each output. See Figure 12. Note that the current bias affects the amplifier bandwidth.
- With total output load capacitance of C_L = 10 pF between the outputs and AC ground.
- Absolute maximum rating is defined as a level or condition that should not be exceeded at any time per the description. If the level or the condition is exceeded, the device will be degraded and may be damaged.

MAXIMUM VOLTAGE RATINGS BETWEEN PINS

Description	Minimum	Maximum	Units	Notes
RL, RR, H1S, H2S, H1BL, H2BL, H1BR, H2BR to ESD	0	17	V	
Pin to Pin with ESD Protection	-17	17	V	1
VDDL, VDDR to GND	0	25	V	

Notes:

- Pins with ESD protection are: RL, RR, H1S, H2S, H1BL, H2BL, H1BR, and H2BR.



DC BIAS OPERATING CONDITIONS

Description	Symbol	Minimum	Nominal	Maximum	Units	Maximum DC Current (mA)	Notes
Output Amplifier Supply	VDD	14.75	15.0	15.25	V	2.5 mA	1, 4
Ground	GND	0.0	0.0	0.0	V		
Substrate	SUB	8.0	VAB	15.0	V		2, 6
ESD Protection	ESD	-9.25	-9.0	-8.75	V	2.0 mA	3
Output Bias Current	Iout	0.0	5.0	10.0	mA		5

Notes:

1. The maximum DC current is for one output unloaded and is shown as $I_{rd} + I_{ss}$ in Figure 12. This is the maximum current that the first two stages of one output amplifier plus the reset drain bias circuit will draw. This value is with V_{out} disconnected.
2. The operating value of the substrate voltage, V_{AB} , will be marked on the shipping container for each device. The shipping container will be marked with two V_{AB} voltages. One V_{AB} will be for a 600mV charge capacity and the other V_{AB} will be for a 1200mV charge capacity. The 600mV charge capacity is for operation of the horizontal clock at frequencies greater than 20 MHz. The 1200mV charge capacity V_{AB} value may be used for horizontal clock frequencies at or below 20MHz.
3. V_{ESD} must be more negative than H1L, H2L and RL during sensors operation AND during camera power turn on.
4. **Both VDDL and VDDR must both be supplied.**
5. One output.
6. Refer to Application Note *Using Interline CCD Image Sensors in High Intensity Visible Lighting Conditions*.

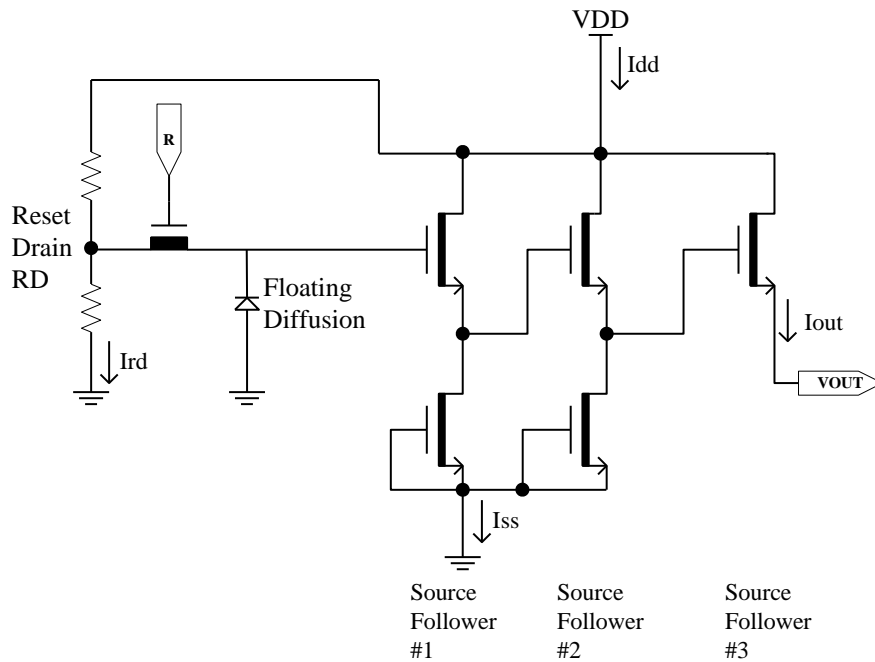

Figure 12: Output Amplifier



AC OPERATING CONDITIONS

Clock Levels

Description	Symbol	Minimum	Nominal	Maximum	Units	Notes
Vertical CCD Clock High	V2H	9.5	+10.0	10.5	V	
Vertical CCD Clocks Midlevel	V1M, V2M	-0.2	+0.0	+0.2	V	
Vertical CCD Clocks Low	V1L, V2L	-9.5	-9.0	-8.5	V	
Horizontal CCD Clocks High	H1H, H2H	-0.5	+0.0	+0.5	V	1
Horizontal CCD Clocks Low	H1L, H2L	-5.5	-5.0	-4.5	V	1
Reset Clock High	RH	+1.5	+2.0	+2.5	V	2
Reset Clock Low	RL	-3.5	-3.0	-2.5	V	2
Electronic Shutter Voltage	VES	44	48	52	V	3
Fast Dump High	FDH	+4.0	+5.0	+5.5	V	
Fast Dump Low	FDL	-9.5	-9.0	-8.5	V	

Notes:

1. The amplitude of the horizontal clock must be at least 4.5 volts.
2. The amplitude of the reset clock must be at least 4.5 volts.
3. Refer to Application Note *Using Interline CCD Image Sensors in High Intensity Visible Lighting Conditions*.

The figure below shows the DC bias (SUB) and AC clock (VES) applied to the SUB pin. Both the DC bias and AC clock are referenced to ground.

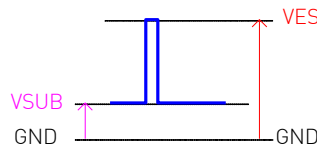

Clock Line Capacitances

PIN	Approximate Capacitance	Units
V1C	3	nF
V1	5	nF
V2	5	nF
V2C	2	nF
H2BL	25	pF
H1BL	25	pF
H1S	40	pF
H2S	40	pF
H1BR	25	pF
H2BR	25	pF
RL	20	pF
RR	20	pF
FD	30	pF
FDC	25	pF



TIMING REQUIREMENTS

Description	Symbol	Minimum	Units	Notes
HCCD Delay	T_{HD}	200	ns	
VCCD Transfer Time	T_{VCCD}	200	ns	
Photodiode Transfer Time	T_{V3rd}	300	ns	
VCCD Pedestal Time	T_{3P}	15	μ s	
VCCD Delay	T_{3D}	5	μ s	
VCCD Frame Delay	T_{3L}	15	μ s	
VCCD Line End Delay	T_{EL}	25	ns	
HCCD Clock Period	T_H	25	ns	1
Reset Pulse Time	T_R	2.5	ns	
Shutter Pulse Time	T_S	1.0	μ s	
Shutter Pulse Delay	T_{SD}	1.0	μ s	
Fast Line Dump Delay	T_{FD}	75	ns	

Description	Symbol	Minimum	Units	Notes
VCCD Clock Overlap	T_{ov}	50	%	

Notes:

- For operation at the minimum HCCD clock period (40MHz), the substrate voltage must be set to limit the signal at the output to 600 mV.
- Each clock pulse width is defined for t_{wh} or t_{wl} .

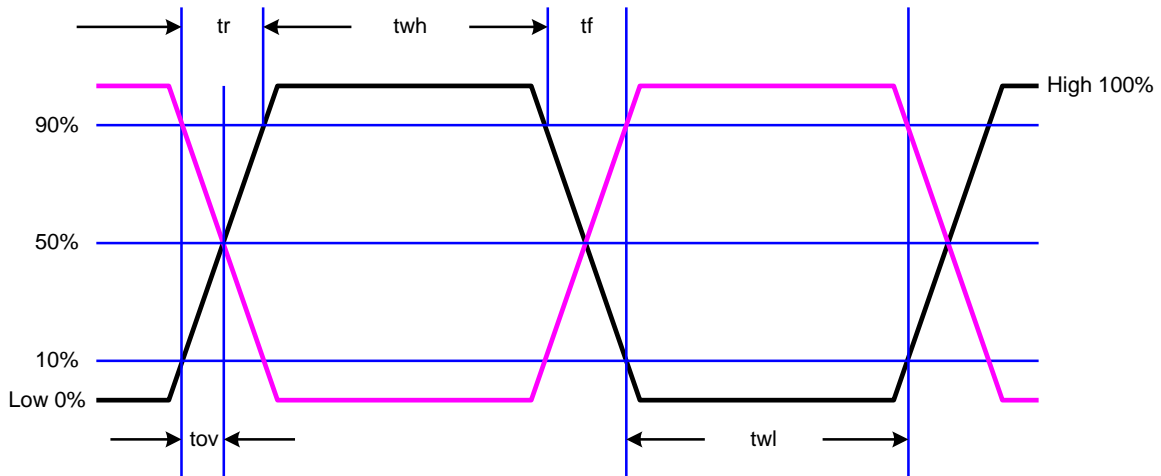



TIMING SEQUENCES

Timing Sequence A: Photodiode to VCCD transfer, Entire Image

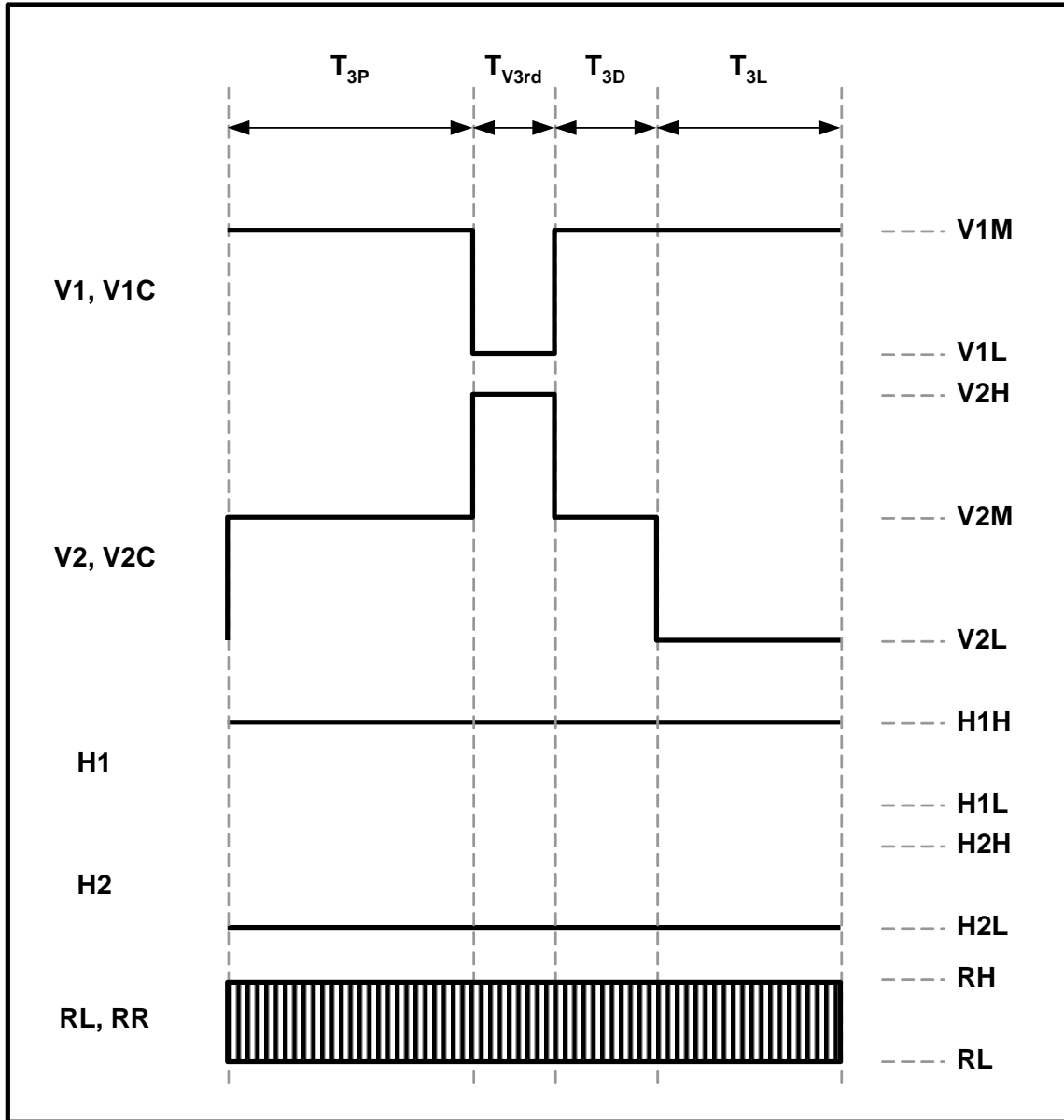

Figure 13: Timing Sequence A



Timing Sequence B: Vertical CCD Line Shift and Horizontal CCD Readout of One Line

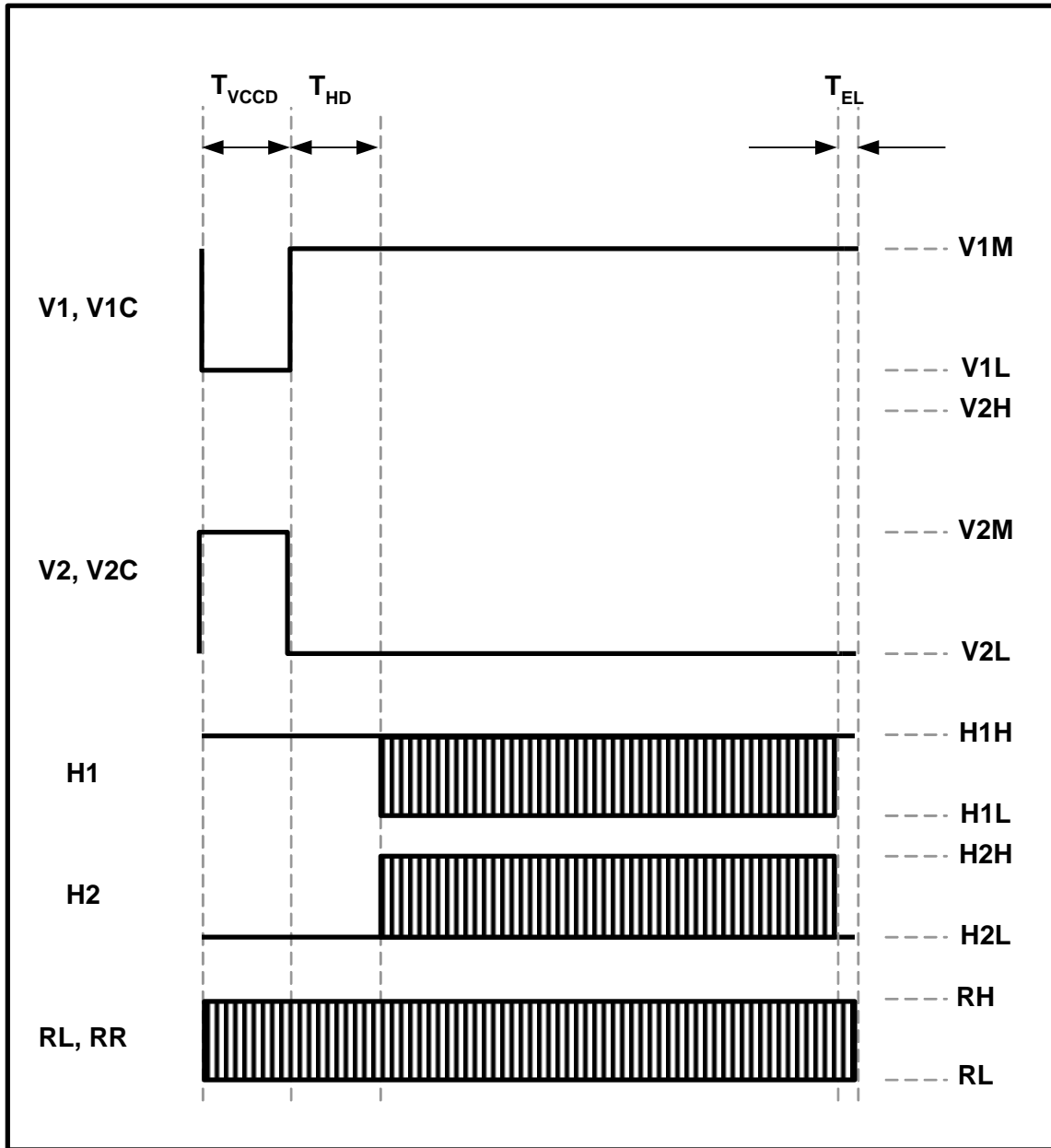

Figure 14: Timing Sequence B



Timing Sequence C: Photodiode to VCCD Transfer, Center 164 Rows

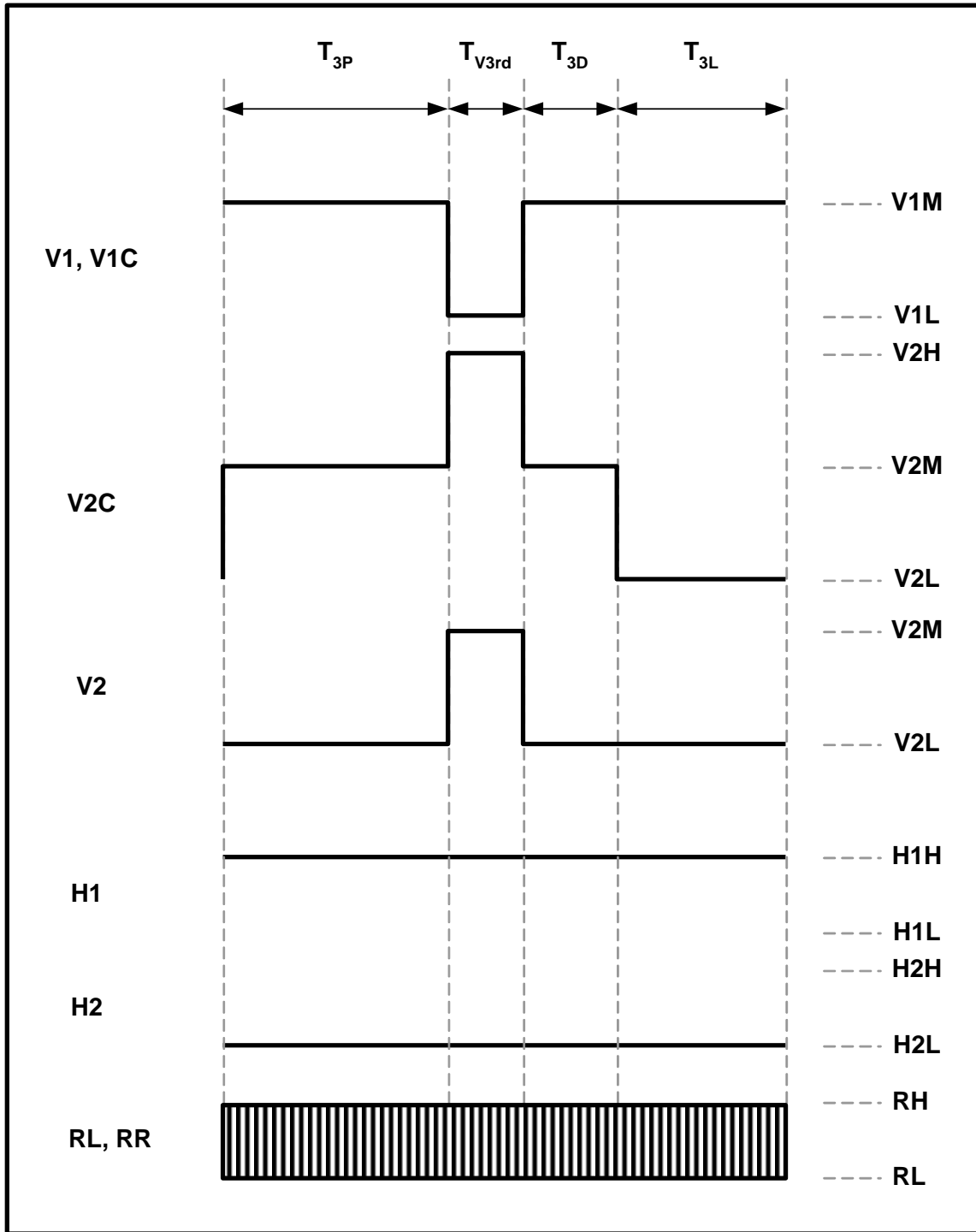

Figure 15: Timing Sequence C



Timing Sequence D: No Vertical CCD Line Transfer, Readout of One Horizontal CCD Line

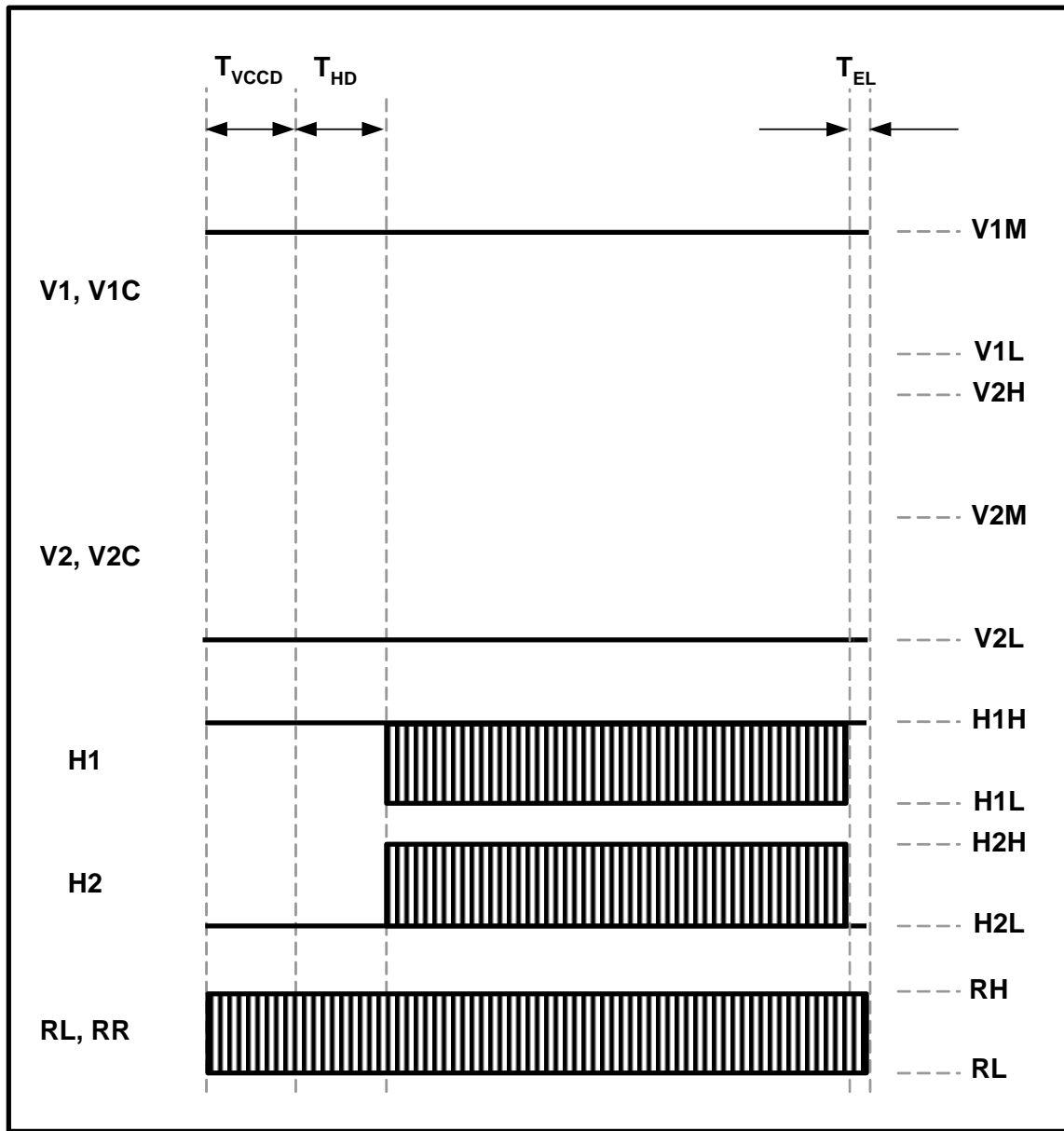
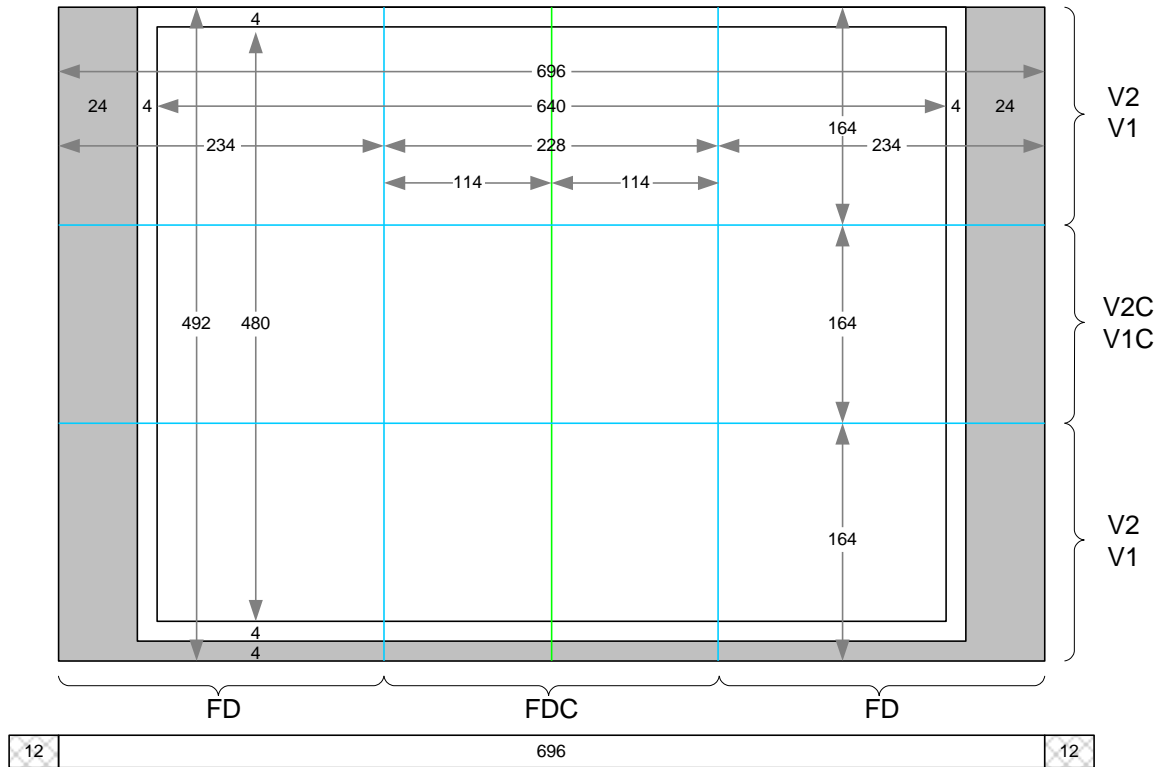

Figure 16: Timing Sequence D



TIMING MODES

Sensor Architecture



When the sensor is operated in single output mode using the left output, the horizontal CCD is 708 pixels long. This assumes no horizontal over clocking is done.

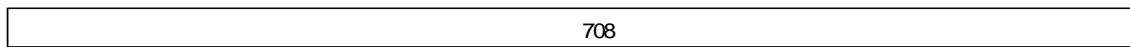

When the sensor is operated in dual output mode, the horizontal CCD is divided into left and right registers. Each half of the register is 360 pixels long. This assumes no horizontal over clocking is done.





One Output Full Field

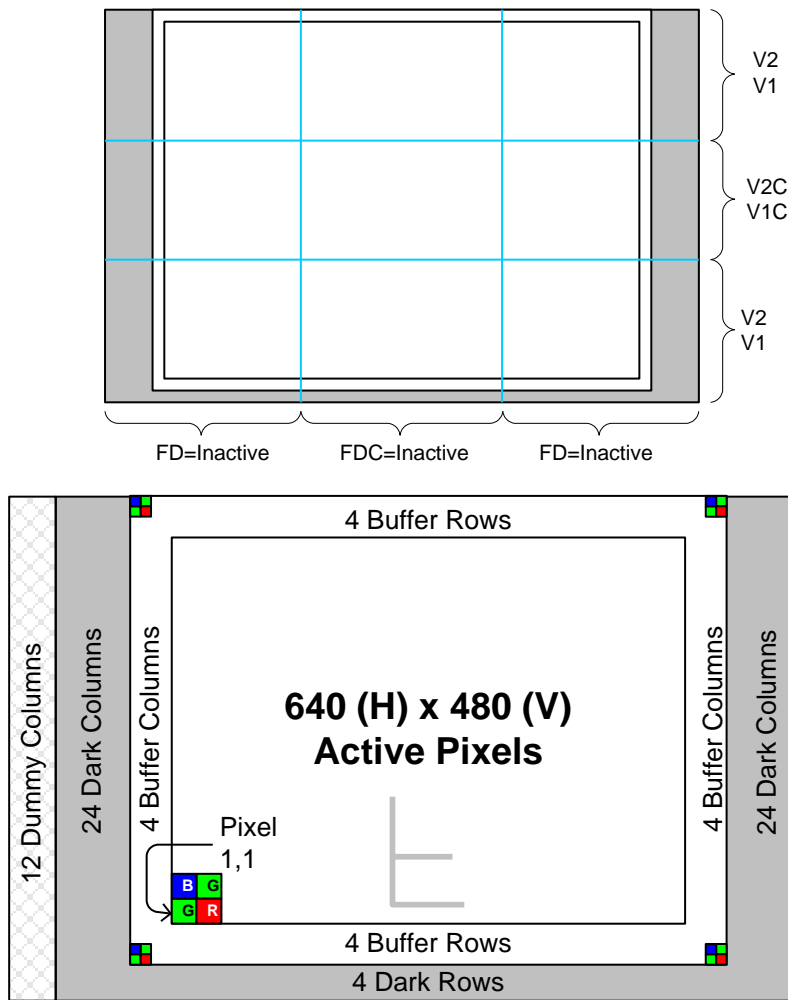

708 HCCD clock cycles per line
492 VCCD clock cycles

VCCD overclocking: allowed
HCCD overclocking: allowed

H1 timing: connect to H1S, H1BL, H2BR
H2 timing: connect to H2S, H2BL, H1BR

FDH = Active
FDL = Inactive

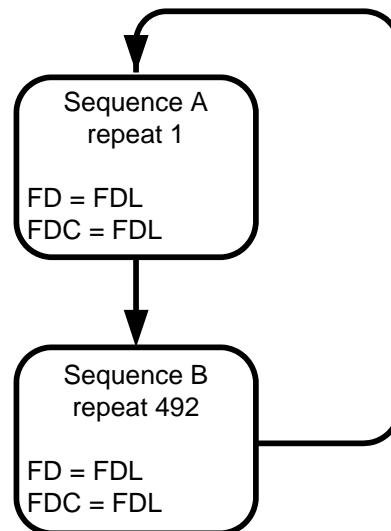



Two Outputs Full Field

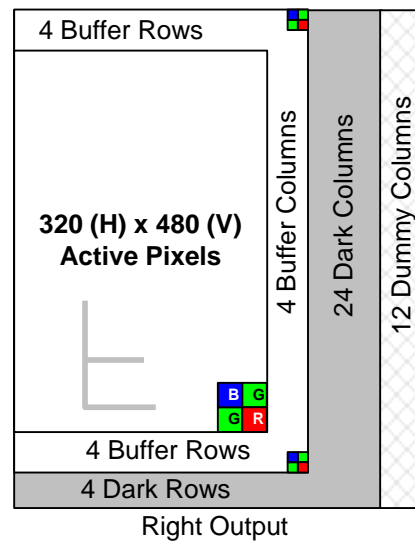
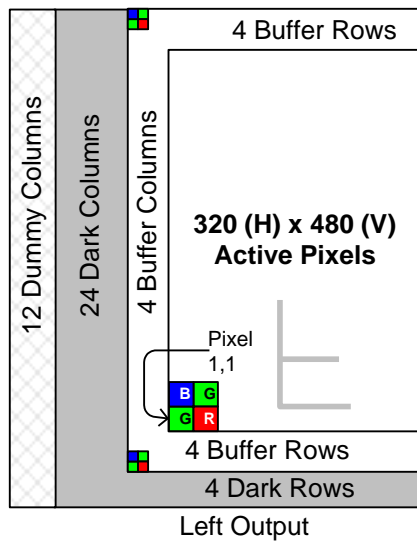
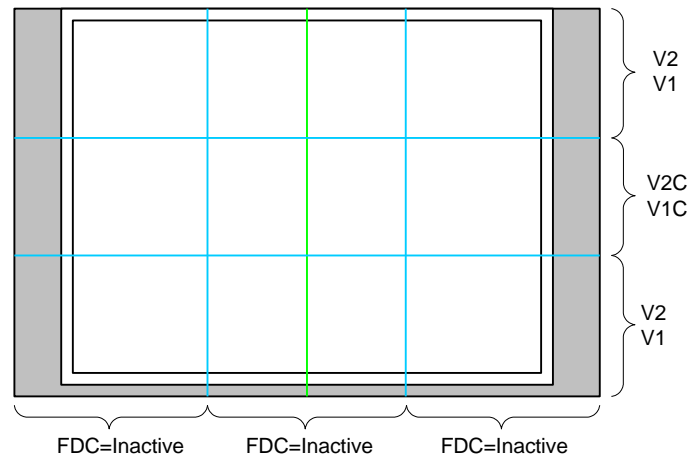

360 HCCD clock cycles per line
492 VCCD clock cycles

VCCD overclocking: allowed
HCCD overclocking: allowed

H1 timing: connect to H1S, H1BL, H1BR
H2 timing: connect to H2S, H2BL, H2BR

FDH = Active
FDL = Inactive

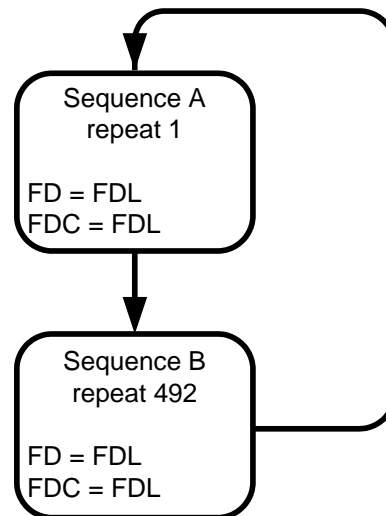



One Output Center Columns

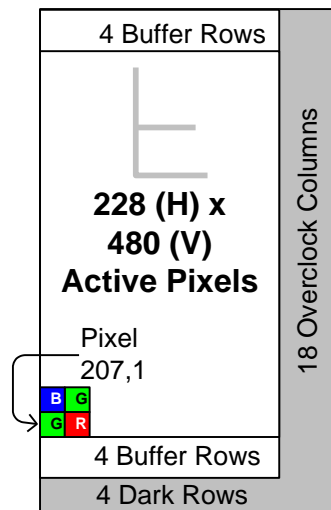
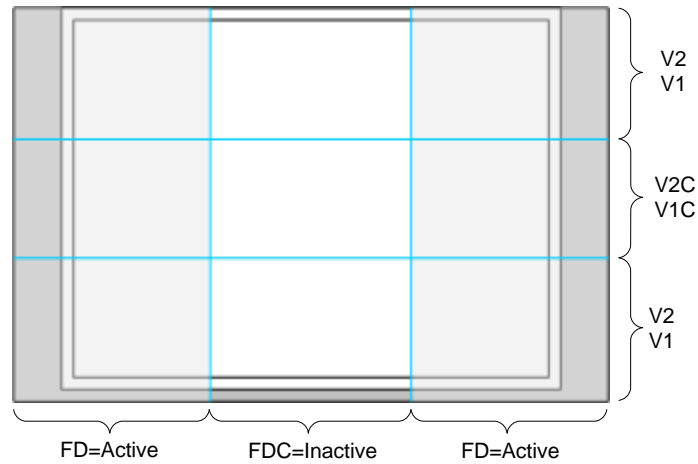

246 HCCD clock cycles per line
492 VCCD clock cycles

VCCD overclocking: allowed
HCCD overclocking: **not** allowed

H1 timing: connect to H1S, H1BL, H2BR
H2 timing: connect to H2S, H2BL, H1BR

FDH = Active
FDL = Inactive

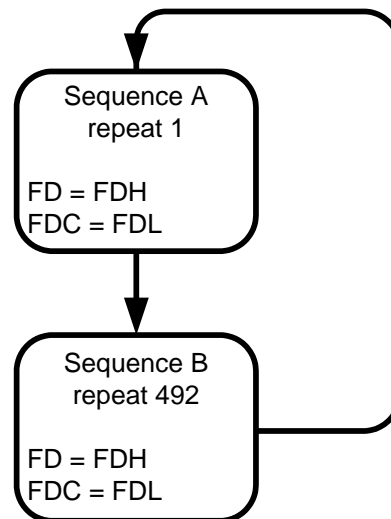



Two Outputs Center Columns

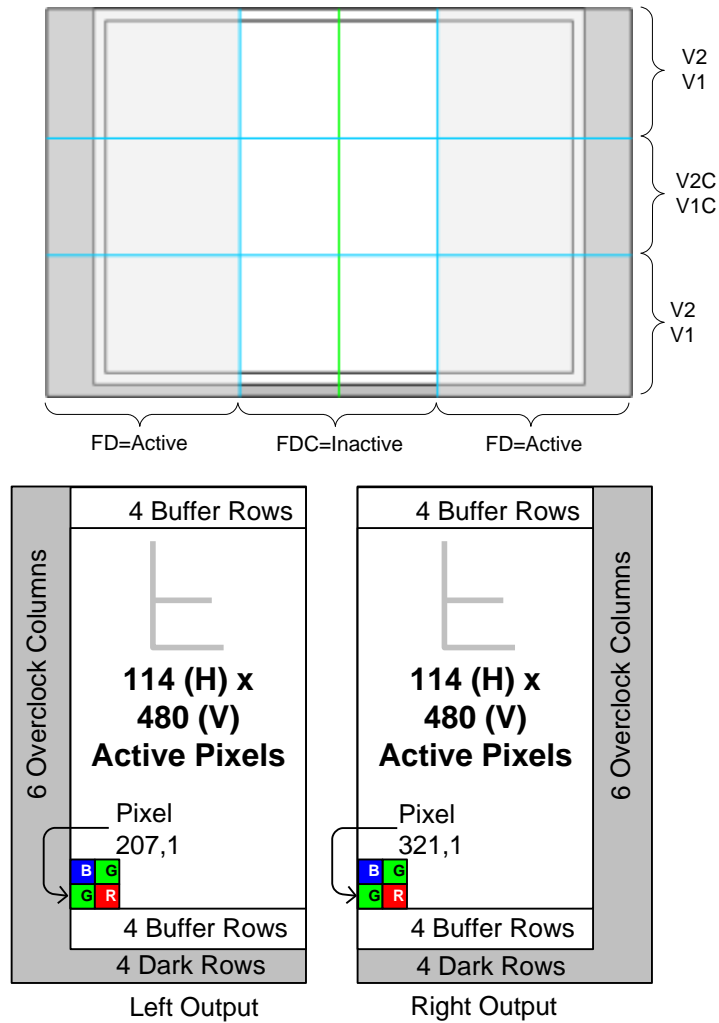

120 HCCD clock cycles per line
492 VCCD clock cycles

VCCD overclocking: allowed
HCCD overclocking: **not** allowed

H1 timing: connect to H1S, H1BL, H1BR
H2 timing: connect to H2S, H2BL, H2BR

FDH = Active
FDL = Inactive

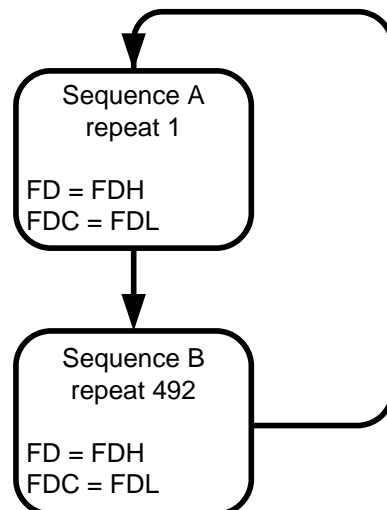



One Output Center Rows

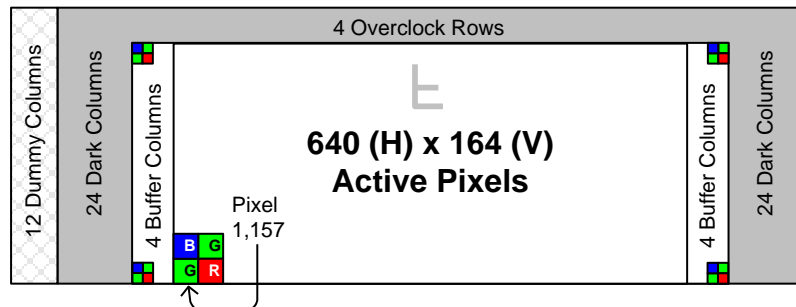
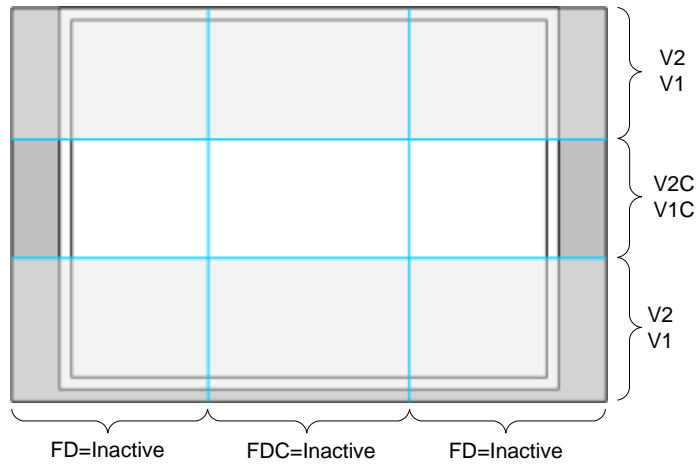

708 HCCD clock cycles per line
163 VCCD clock cycles

VCCD overclocking: **not** allowed
HCCD overclocking: allowed

H1 timing: connect to H1S, H1BL, H2BR
H2 timing: connect to H2S, H2BL, H1BR

FDH = Active
FDL = Inactive

Omit this step if the 4
overclock rows are
not needed

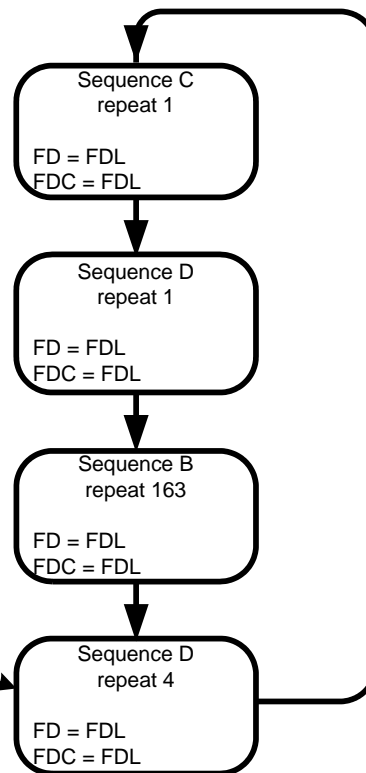



Two Outputs Center Rows

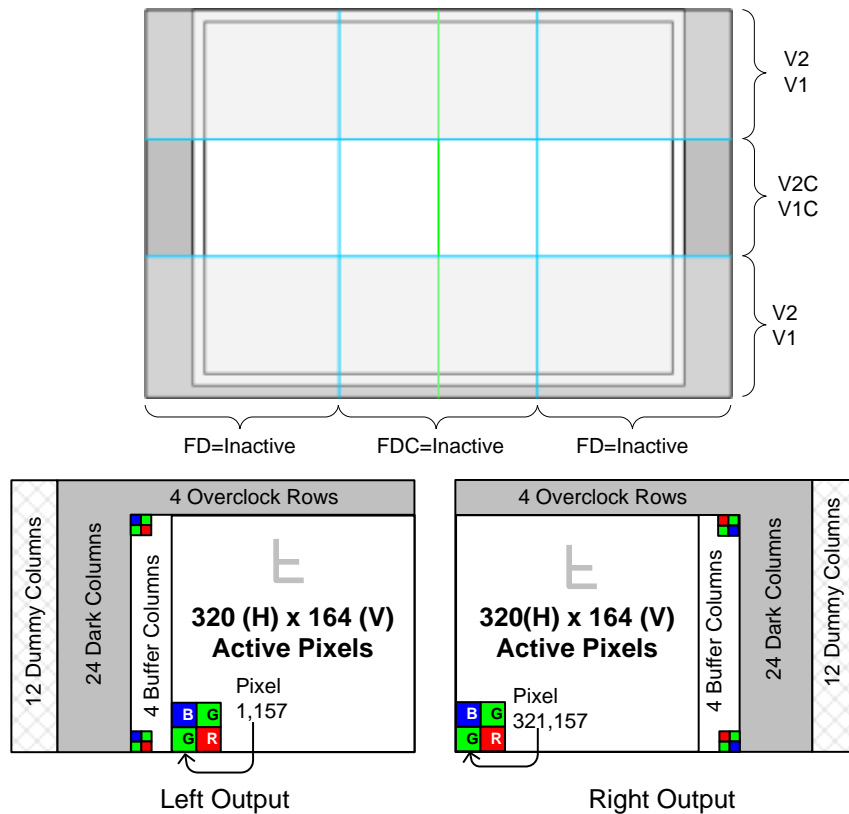

360 HCCD clock cycles per line
163 VCCD clock cycles

VCCD overlocking: **not** allowed
HCCD overlocking: allowed

H1 timing: connect to H1S, H1BL, H1BR
H2 timing: connect to H2S, H2BL, H2BR

FDH = Active
FDL = Inactive

Omit this step if the 4
overclock rows are
not needed

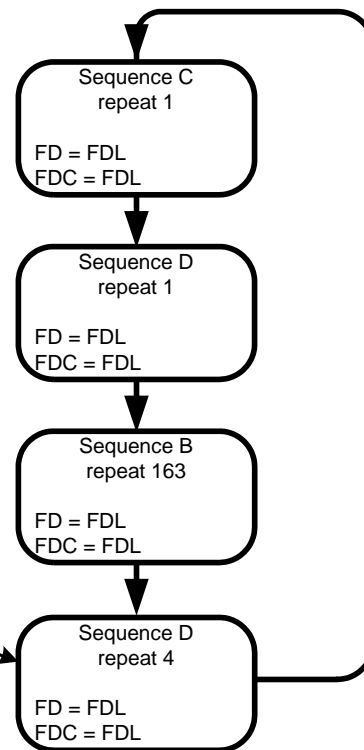



One Output Center Rows and Columns

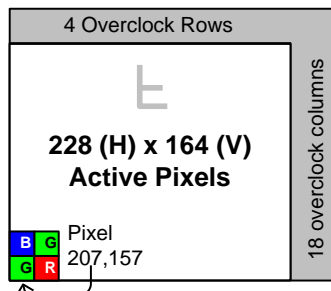
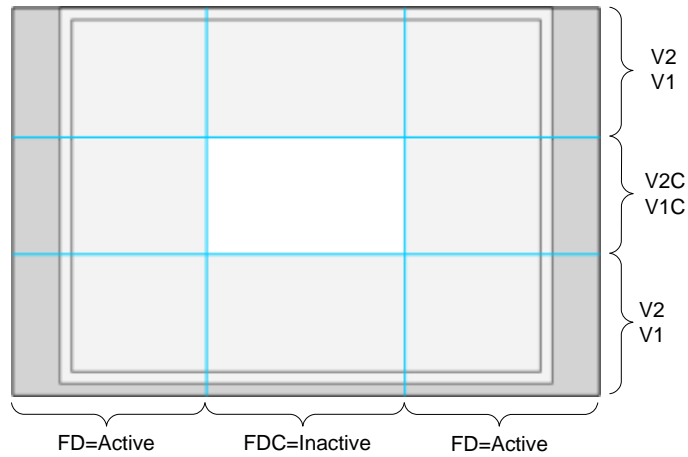

246 HCCD clock cycles per line
163 VCCD clock cycles

VCCD overlocking: **not** allowed
HCCD overlocking: **not** allowed

H1 timing: connect to H1S, H1BL, H2BR
H2 timing: connect to H2S, H2BL, H1BR

FDH = Active
FDL = Inactive

Omit this step if the 4 overlock rows are not needed

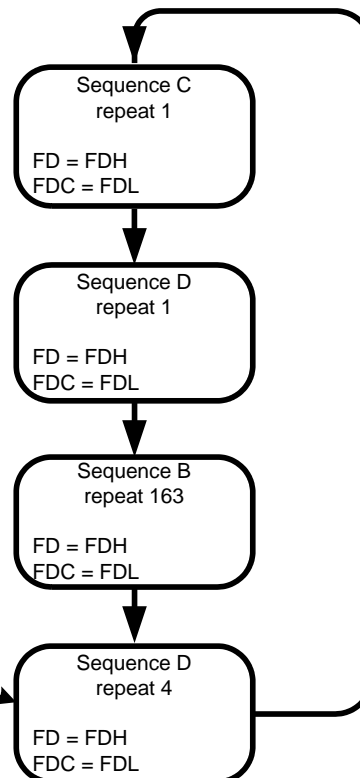



Two Outputs Center Rows and Columns

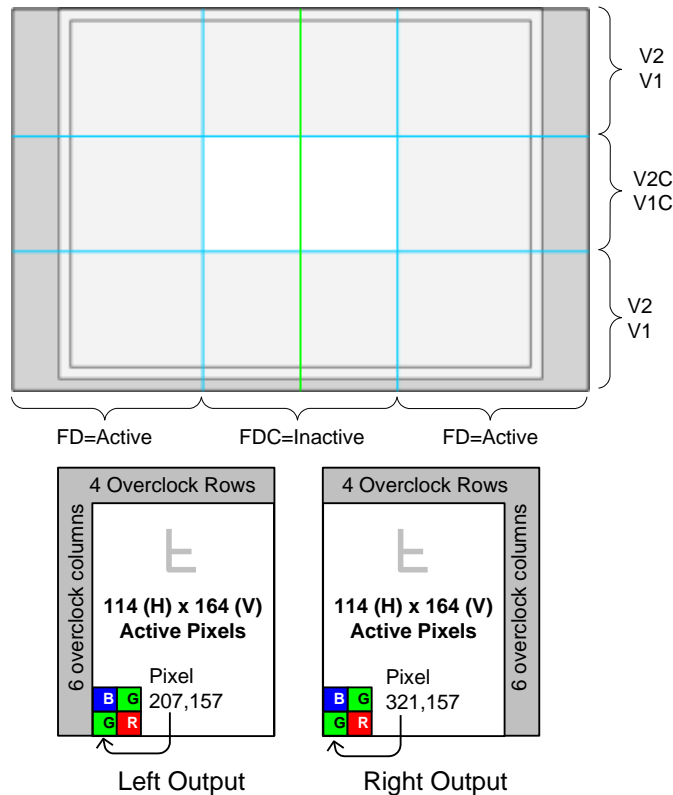

120 HCCD clock cycles per line
163 VCCD clock cycles

VCCD overclocking: **not** allowed
HCCD overclocking: **not** allowed

H1 timing: connect to H1S, H1BL, H1BR
H2 timing: connect to H2S, H2BL, H2BR

FDH = Active
FDL = Inactive

Omit this step if the 4 over clock rows are not needed

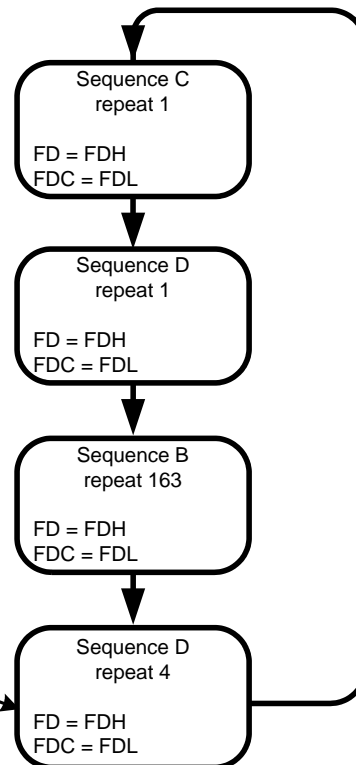



TIMING DETAILS

Pixel Timing

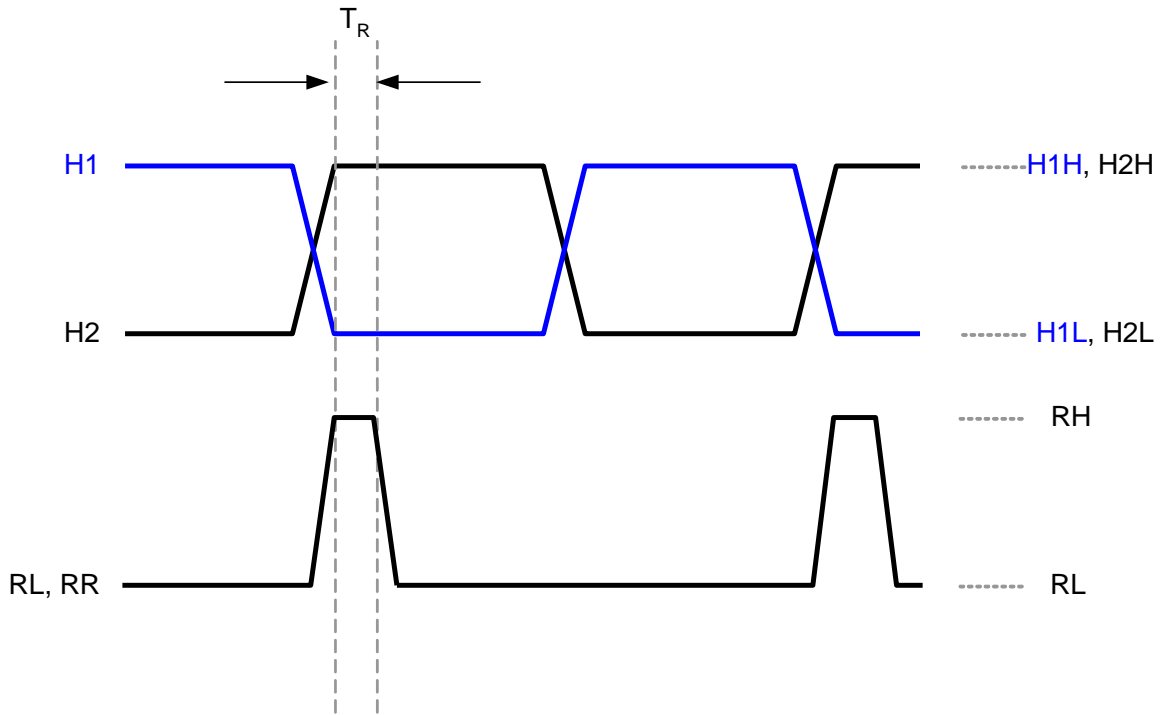

Figure 17: Pixel Timing Detail



Vertical Clock Phase 1 – Line Timing Detail

The following timing detail applies if any of the center row timing modes are selected. If the center row timing modes are not to be used, then the V1 and V1C pins should be tied together and driven from one clock driver.

During the line timing, the V1 and V1C rise and fall times need to be identical. Since the V1 capacitance is approximately twice the V1C capacitance, the clock driver circuits must be adjusted to ensure equal rise and fall times.

The figure below is an example of unacceptable V1 and V1C clock waveforms.

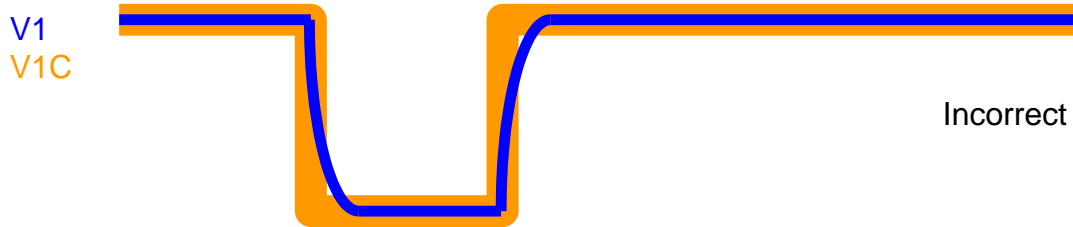

The figures below are examples of acceptable V1 and V1C clock waveforms.

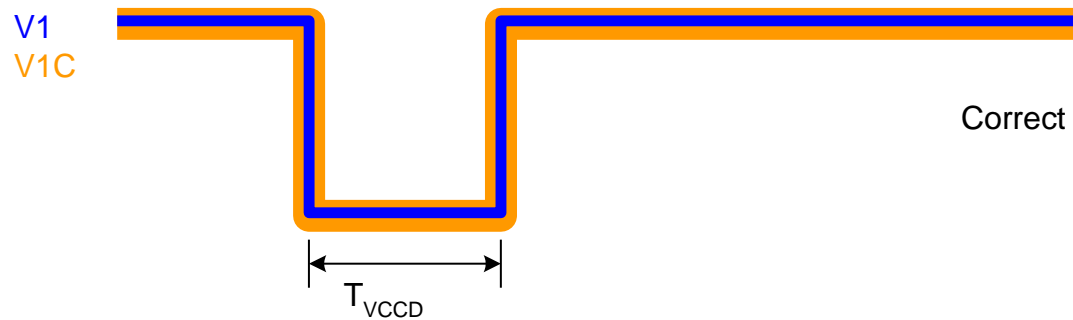
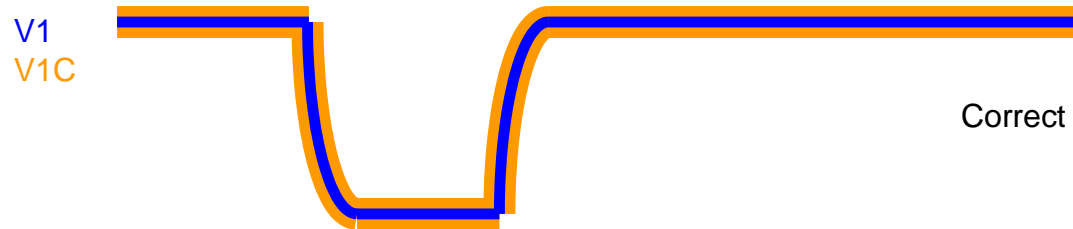



Vertical Clock Phase 2 – Line Timing Detail

The following timing detail applies if any of the center row timing modes are selected. If the center row timing modes are not to be used, then the V2 and V2C pins should be tied together and driven from one clock driver.

During the line timing, the V2 and V2C rise and fall times need to be identical. Since the V2 capacitance is approximately twice the V2C capacitance, the clock driver circuits must be adjusted to ensure equal rise and fall times.

The figure below is an example of unacceptable V2 and V2C clock waveforms.

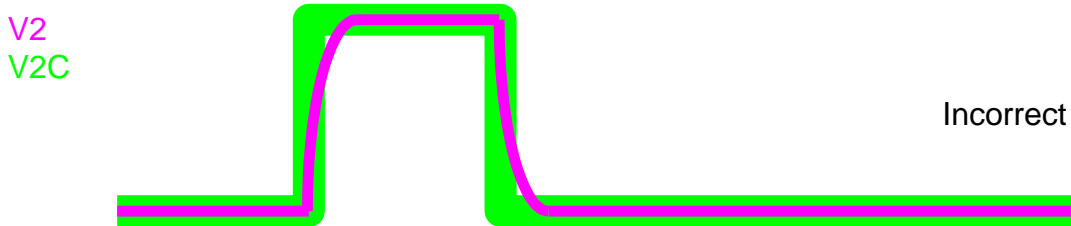

The figures below are examples of acceptable V2 and V2C clock waveforms.

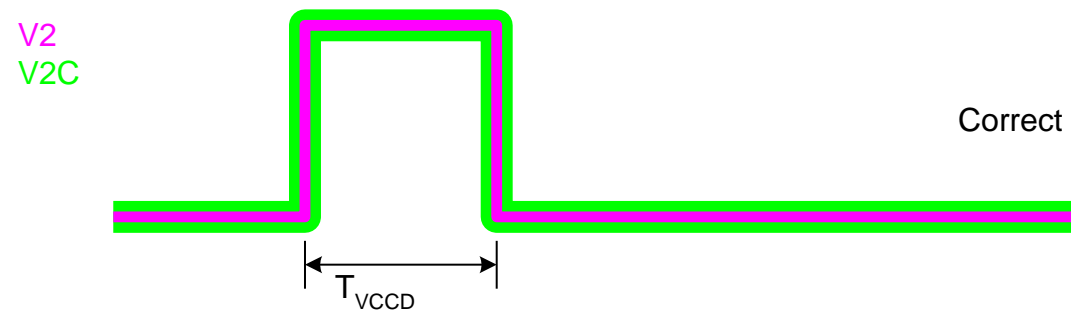
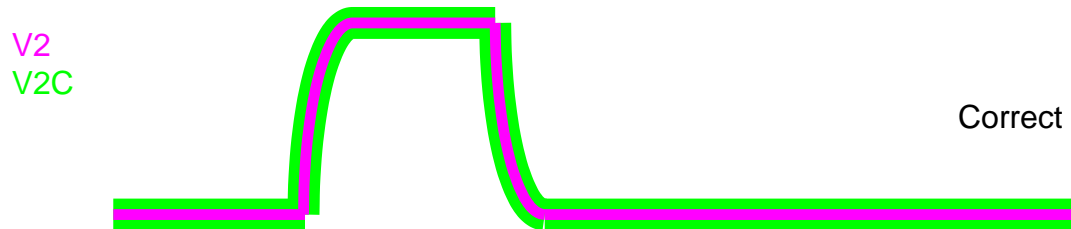



Vertical Clocks Phases 1 and 2 – Line Timing Detail

The following line timing detail applies to all modes.

The V1 and V1C clocks must be symmetrical to the V2 and V2C clocks. The figure below is an example of unacceptable V1, V1C, V2 and V2C clock waveforms.

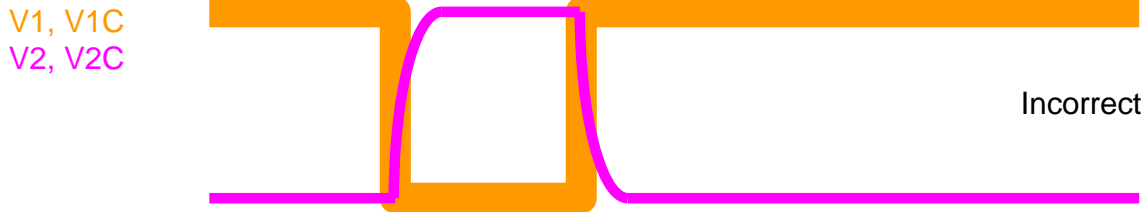

The figures below are of acceptable V1, V1C, V2 and V2C clock waveforms.

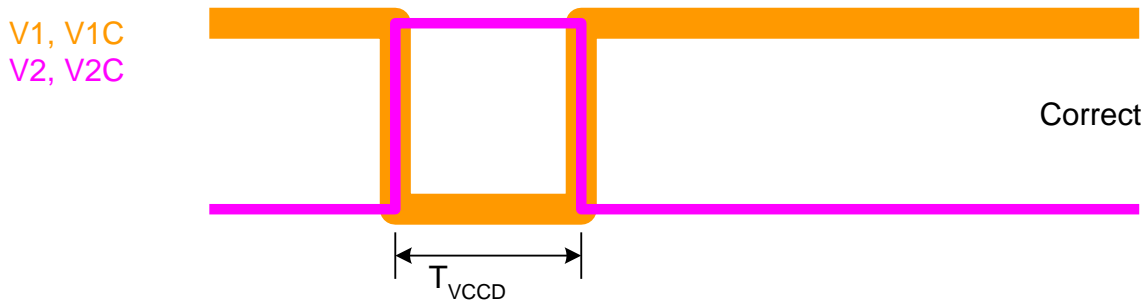
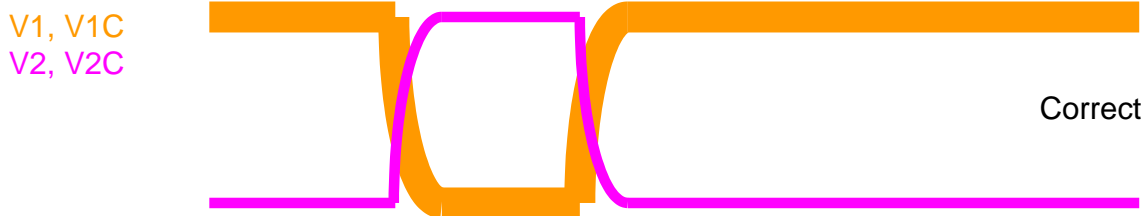



Vertical Clock Phase 1 – Frame Timing Detail

The following timing detail applies if any of the center row timing modes are selected. If the center row timing modes are not to be used, then the V1 and V1C pins should be tied together and driven from one clock driver.

During the frame timing, the V1 and V1C rise and fall times need to be identical. Since the V1 capacitance is approximately twice the V1C capacitance, the clock driver circuits must be adjusted to ensure equal rise and fall times.

The figure below is an example of unacceptable V1 and V1C clock waveforms.

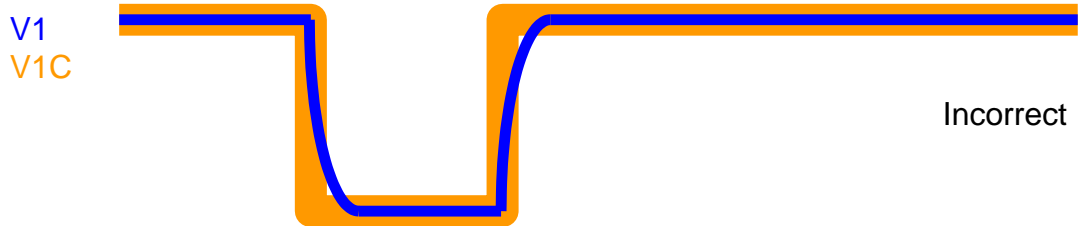

The figures below are examples of acceptable V1 and V1C clock waveforms

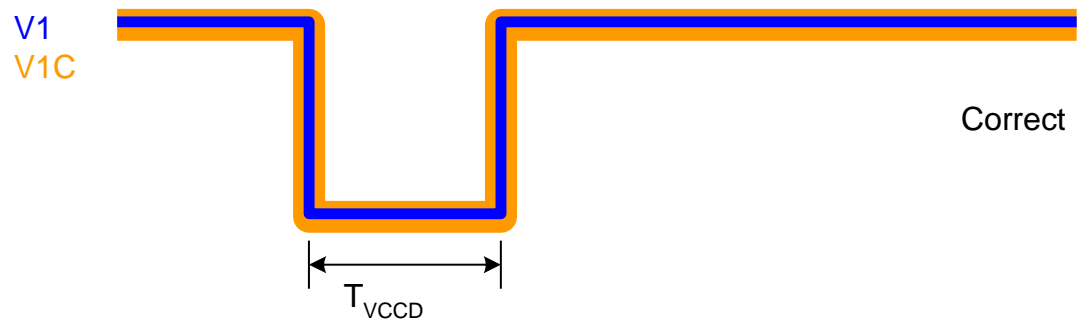
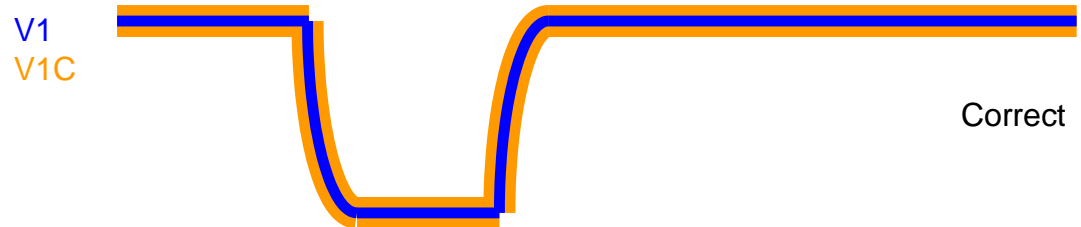



Vertical Clock Phase 2 – Frame Timing Detail

The following timing detail applies if any of the center row timing modes are selected. If the center row timing modes are not to be used, then the V2 and V2C pins should be tied together and driven from one clock driver.

During the frame timing, the V2 and V2C rise and fall times need to be identical. Since the V2 capacitance is approximately twice the V2C capacitance, the clock driver circuits must be adjusted to ensure equal rise and fall times.

The figure below is an example of unacceptable V2 and V2C clock waveforms during the frame timing.

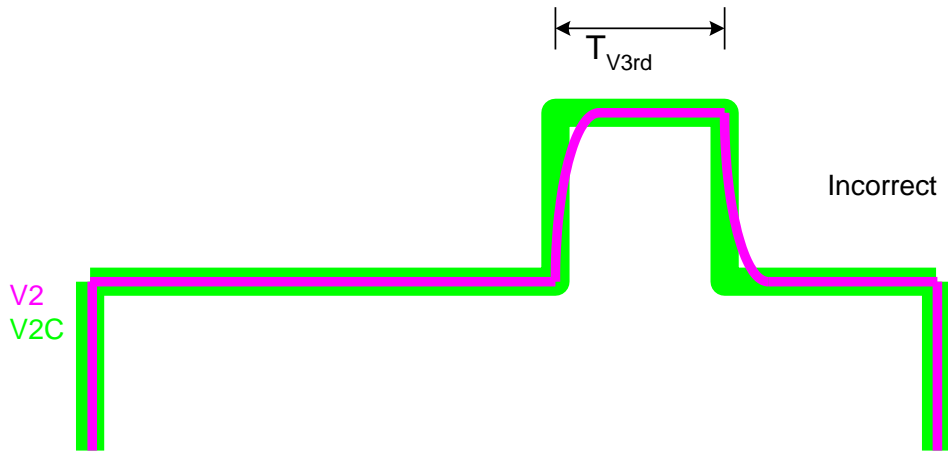

The figures below are examples of acceptable V2 and V2C clock waveforms during the frame timing.

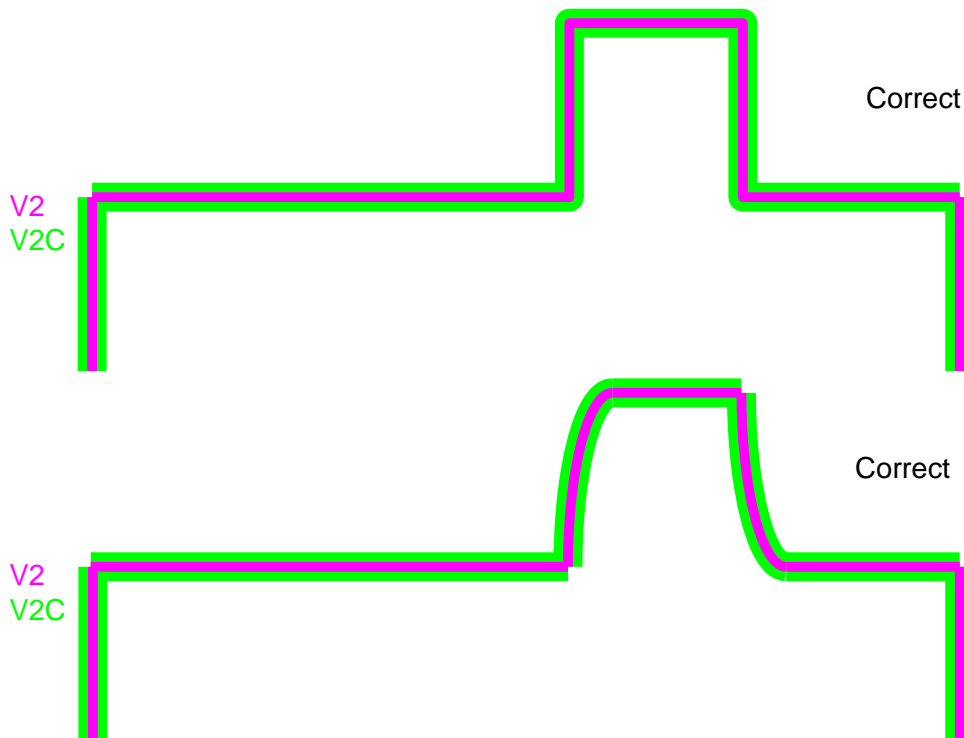



Vertical Clocks Phases 1 and 2 – Frame Timing Detail

The following frame timing detail applies to all modes.

The V1 and V1C clocks must be symmetrical to the V2 and V2C clocks. Also, during the T_{V3rd} timing, the V1 and V2 waveform edges should be aligned to occur at the same time.

The figure below is an example of unacceptable V1, V1C, V2 and V2C clock waveforms.

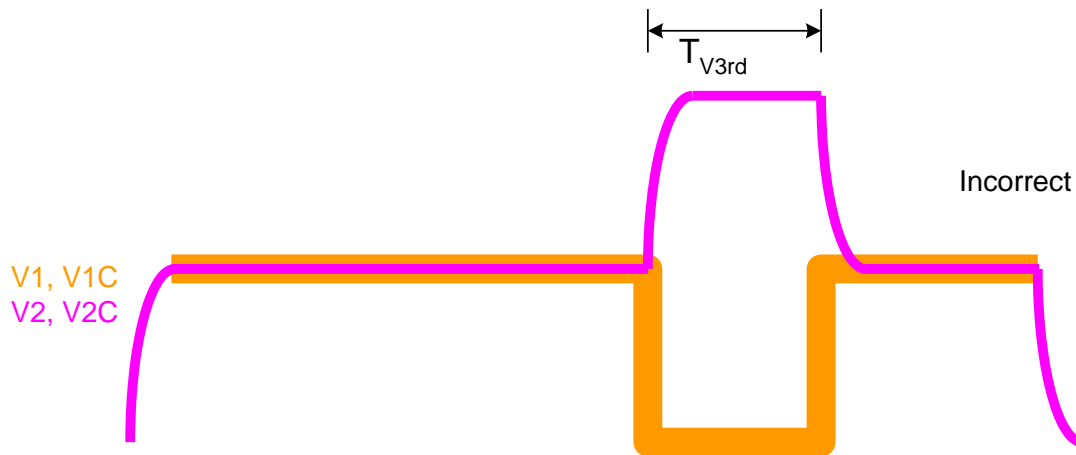

The figures below are of acceptable V1, V1C, V2 and V2C clock waveforms.

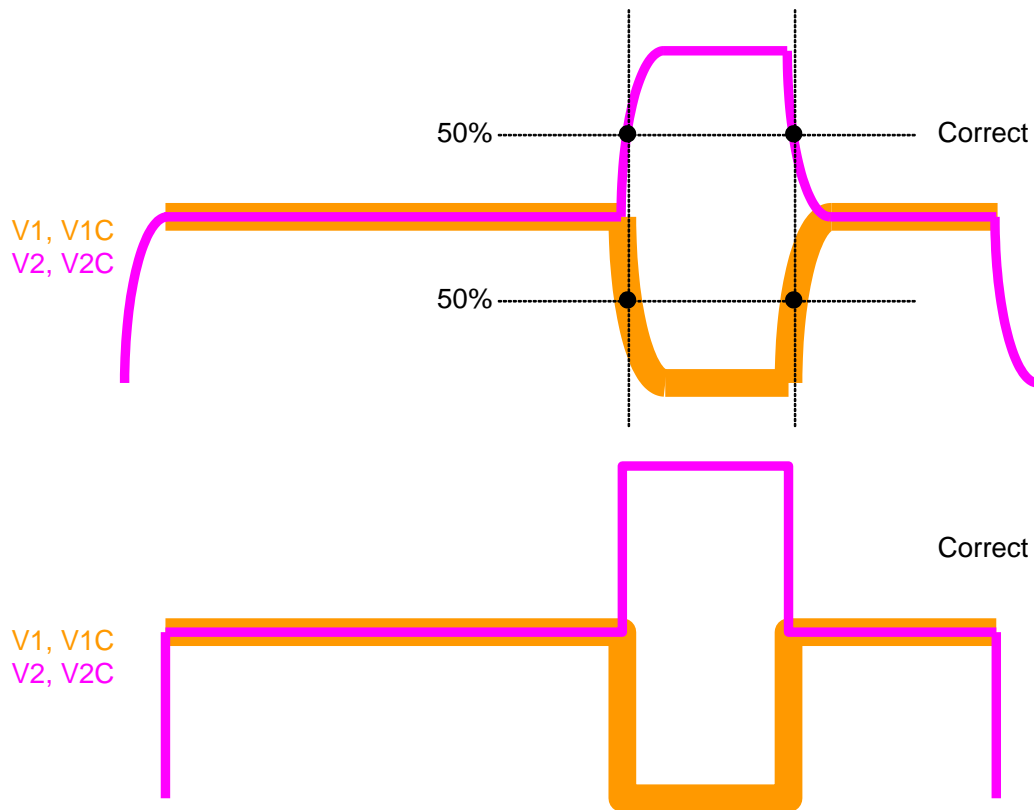



Electronic Shutter Timing

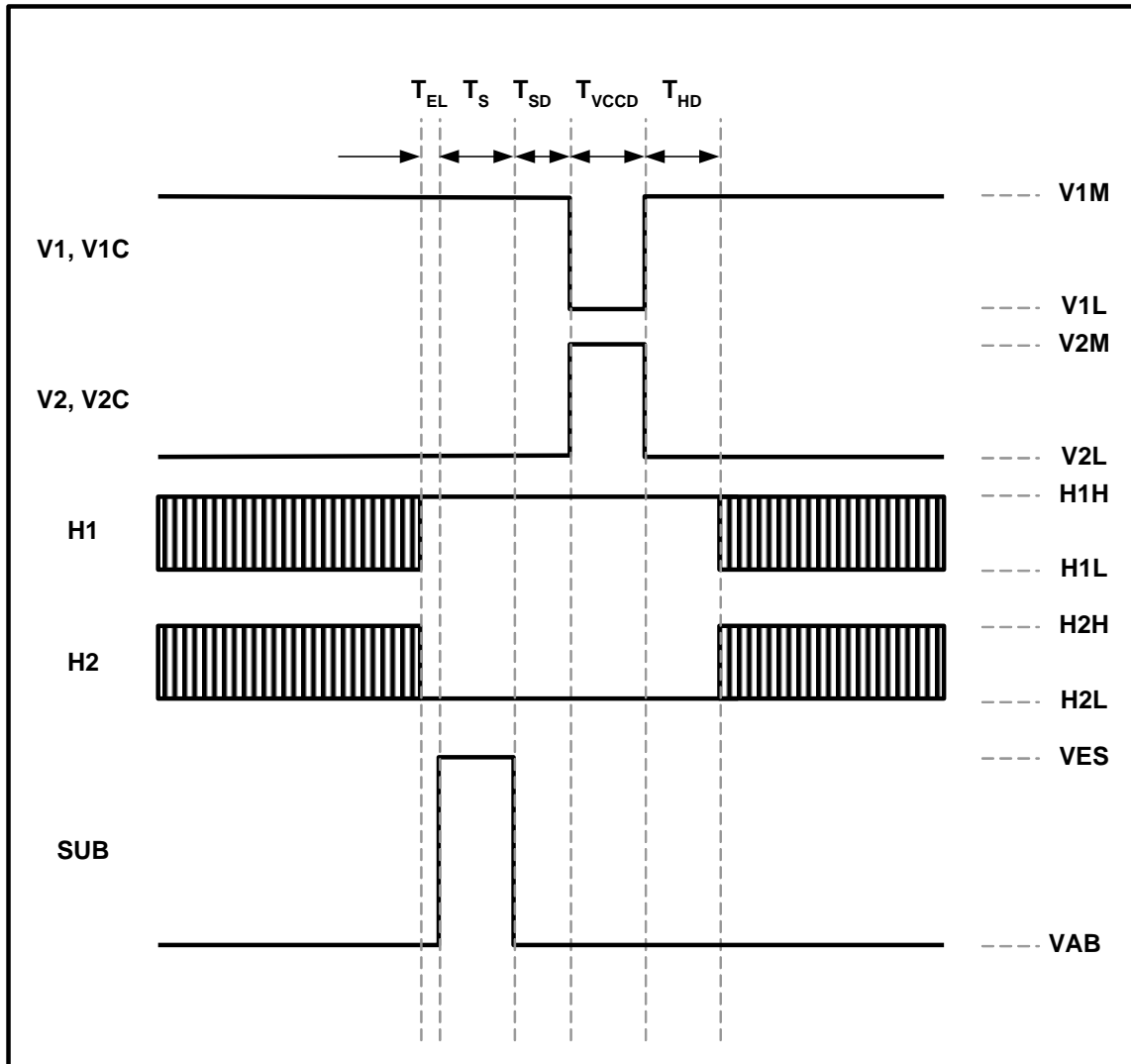

Figure 18: Electronic Shutter Timing



Electronic Shutter – Integration Time Definition

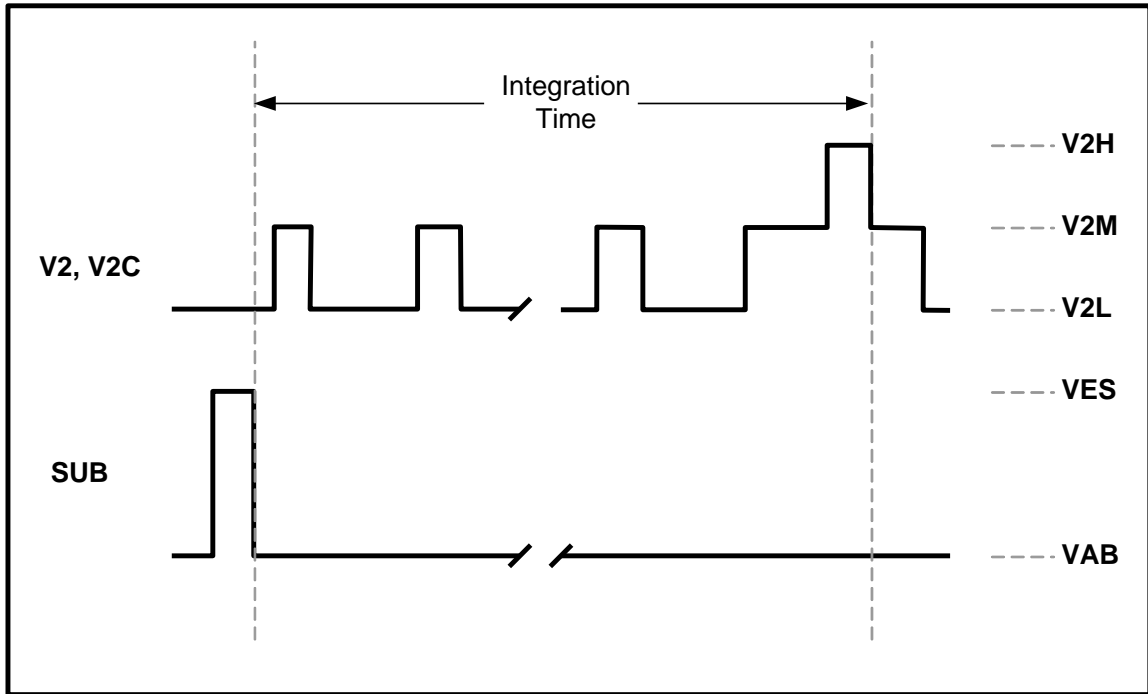

Figure 19: Integration Time Definition



Fast Line Dump Timing

The figure below shows an example of dumping three lines for all rows.

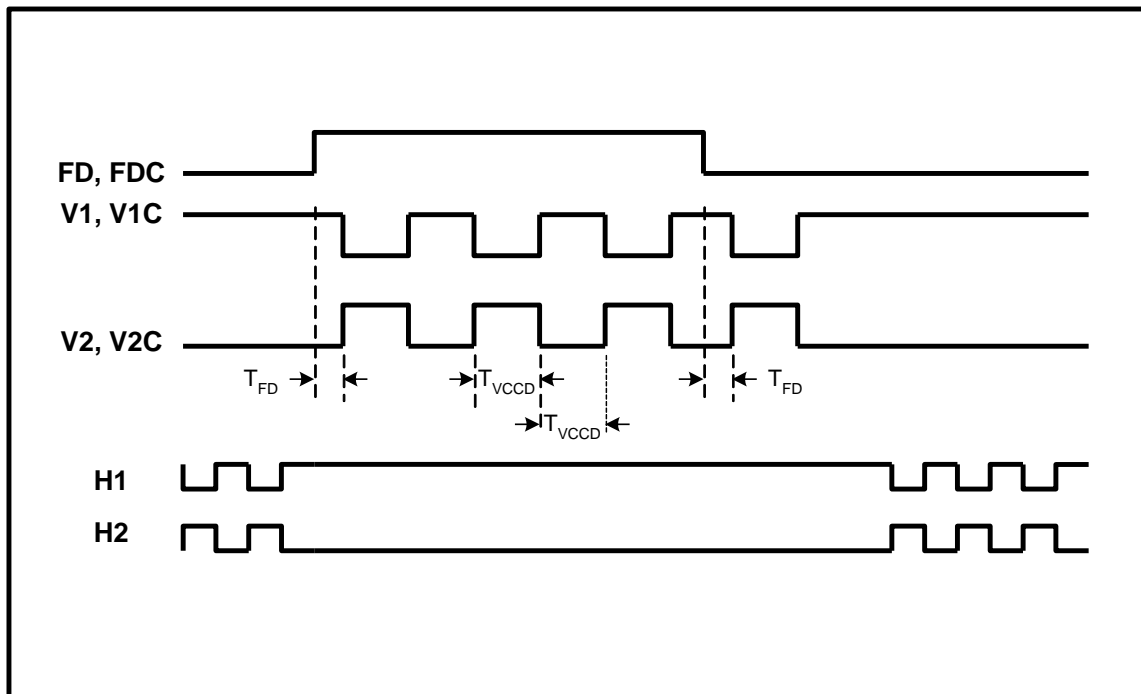

Figure 20: Fast Line Dump Timing



EXAMPLE HCCD CLOCK DRIVER

The HCCD clock inputs should be driven by buffers capable of driving a capacitance of 40 pF and having a full voltage swing of at least 4.7 Volts. A 74AC04 or equivalent is recommended to drive the HCCD. The HCCD requires a 0.0 to – 5.0 V clock. This clock level can be obtained by capacitive coupling and a diode to clamp the high level to ground. Resistors R2 and R6 are used to dampen the signal to prevent overshoots. The values of resistors R2 and R6 shown in the schematics below are only suggestions. The actual value required should be selected for each camera design.

Single Output Only

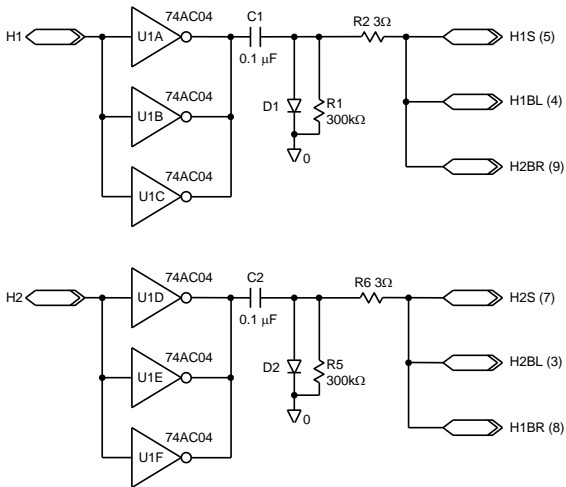

Dual Output Only

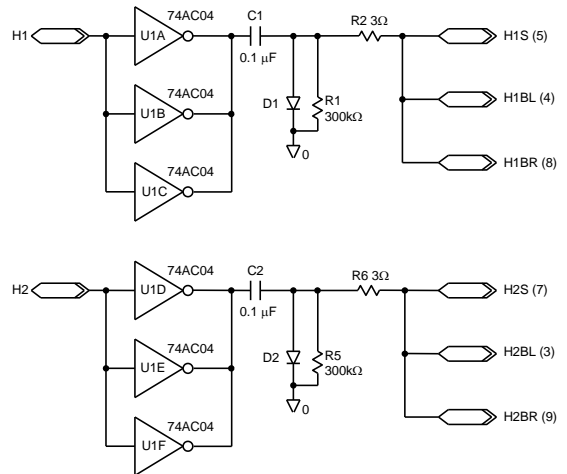

Selectable Single or Dual Output

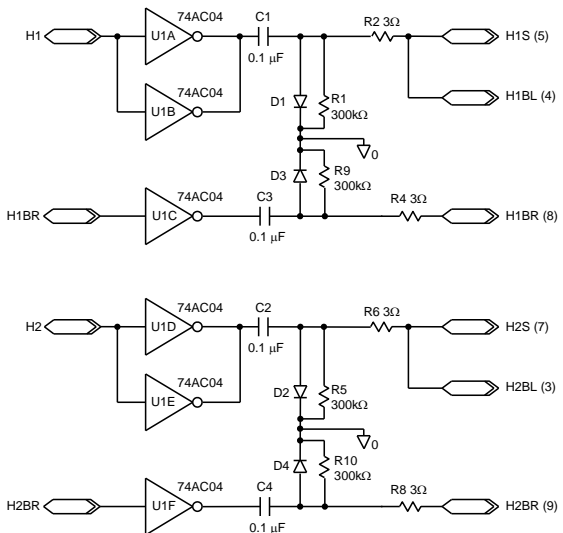

The inputs to the above circuits, H1 and H2, are 5V logic from the timing generator (a programmable gate array for example). If the camera is to have selectable single or dual output modes of operation, then the timing logic needs to generate two extra signals for the H1BR and H2BR timing. For single output mode program the timing such that H1BR=H2 and H2BR=H1. For dual output mode program the timing such that H1BR=H1 and H2BR=H2.



Storage and Handling

STORAGE CONDITIONS

Description	Symbol	Minimum	Maximum	Units	Notes
Temperature	T _{ST}	-55	80	°C	1
Humidity	RH	5	90	%	2

Notes:

1. Long-term exposure toward the maximum temperature will accelerate color filter degradation.
2. T=25 °C. Excessive humidity will degrade MTTF.

ESD

1. This device contains limited protection against Electrostatic Discharge (ESD). ESD events may cause irreparable damage to a CCD image sensor either immediately or well after the ESD event occurred. Failure to protect the sensor from electrostatic discharge may affect device performance and reliability.
2. Devices should be handled in accordance with strict ESD procedures for Class 0 (<250V per JESD22 Human Body Model test), or Class A (<200V JESD22 Machine Model test) devices. Devices are shipped in static-safe containers and should only be handled at static-safe workstations.
3. See Application Note *Image Sensor Handling Best Practices* for proper handling and grounding procedures. This application note also contains workplace recommendations to minimize electrostatic discharge.
4. Store devices in containers made of electro-conductive materials.

COVER GLASS CARE AND CLEANLINESS

1. The cover glass is highly susceptible to particles and other contamination. Perform all assembly operations in a clean environment.
2. Touching the cover glass must be avoided.
3. Improper cleaning of the cover glass may damage these devices. Refer to Application Note *Image Sensor Handling Best Practices*.

ENVIRONMENTAL EXPOSURE

1. Extremely bright light can potentially harm CCD image sensors. Do not expose to strong sunlight for long periods of time, as the color filters and/or microlenses may become discolored. In addition, long time exposures to a static high contrast scene should be avoided. Localized changes in response may occur from color filter/microlens aging. For Interline devices, refer to Application Note *Using Interline CCD Image Sensors in High Intensity Visible lighting Conditions*.
2. Exposure to temperatures exceeding maximum specified levels should be avoided for storage and operation, as device performance and reliability may be affected.
3. Avoid sudden temperature changes.
4. Exposure to excessive humidity may affect device characteristics and may alter device performance and reliability, and therefore should be avoided.
5. Avoid storage of the product in the presence of dust or corrosive agents or gases, as deterioration of lead solderability may occur. It is advised that the solderability of the device leads be assessed after an extended period of storage, over one year.

SOLDERING RECOMMENDATIONS

1. The soldering iron tip temperature is not to exceed 370 °C. Higher temperatures may alter device performance and reliability.
2. Flow soldering method is not recommended. Solder dipping can cause damage to the glass and harm the imaging capability of the device. Recommended method is by partial heating using a grounded 30 W soldering iron. Heat each pin for less than 2 seconds duration.



Mechanical Drawings

COMPLETED ASSEMBLY

SHOWN WITH SEALED COVER GLASS

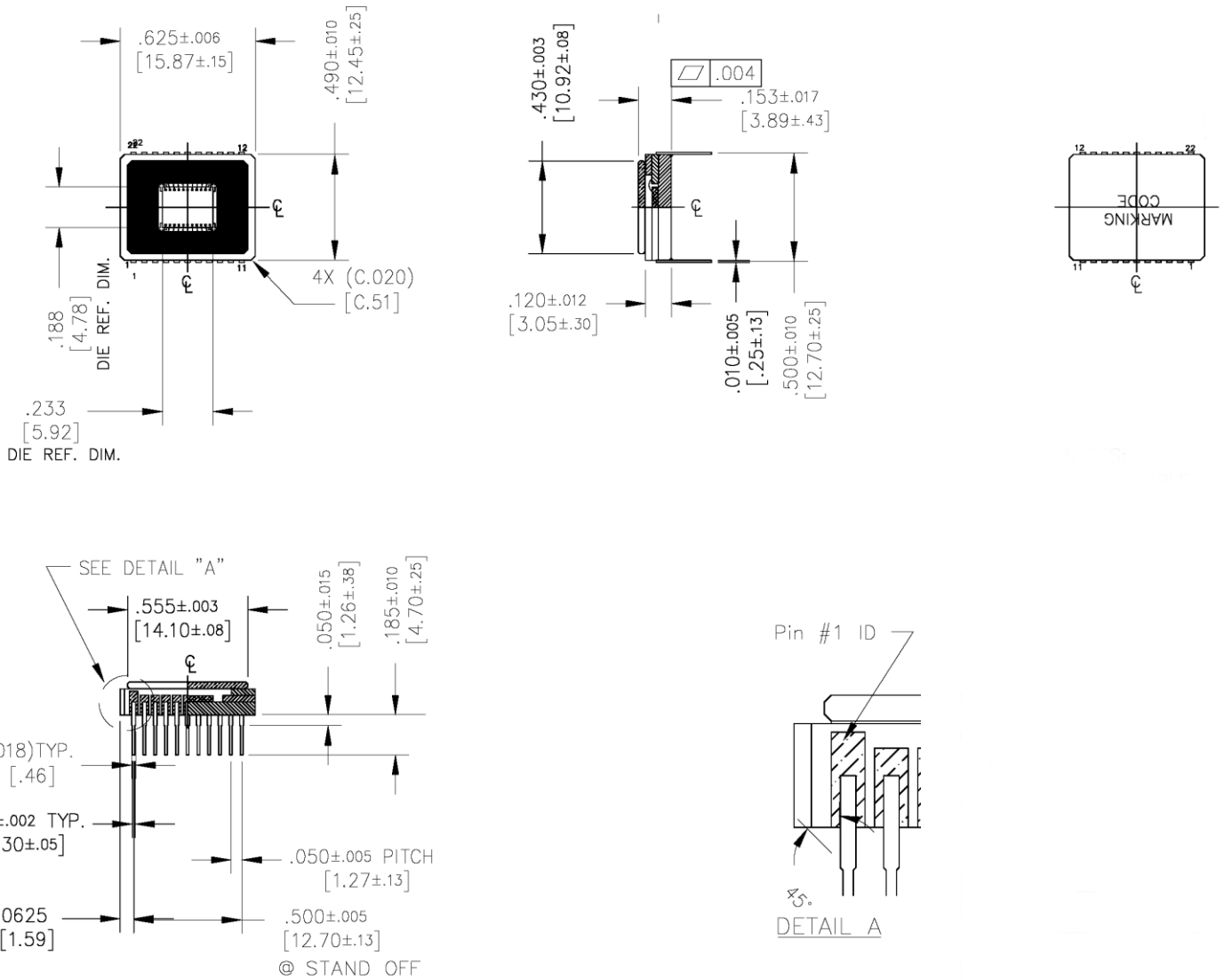

Figure 21: Completed Assembly

Notes:

1. Units: IN [mm]
2. See Available Part Configurations in Ordering Section for a description of the marking code.
3. Lid shall not extend beyond ceramic edge.
4. Light shield shown for reference only. Quartz version is smaller.



DIE TO PACKAGE ALIGNMENT

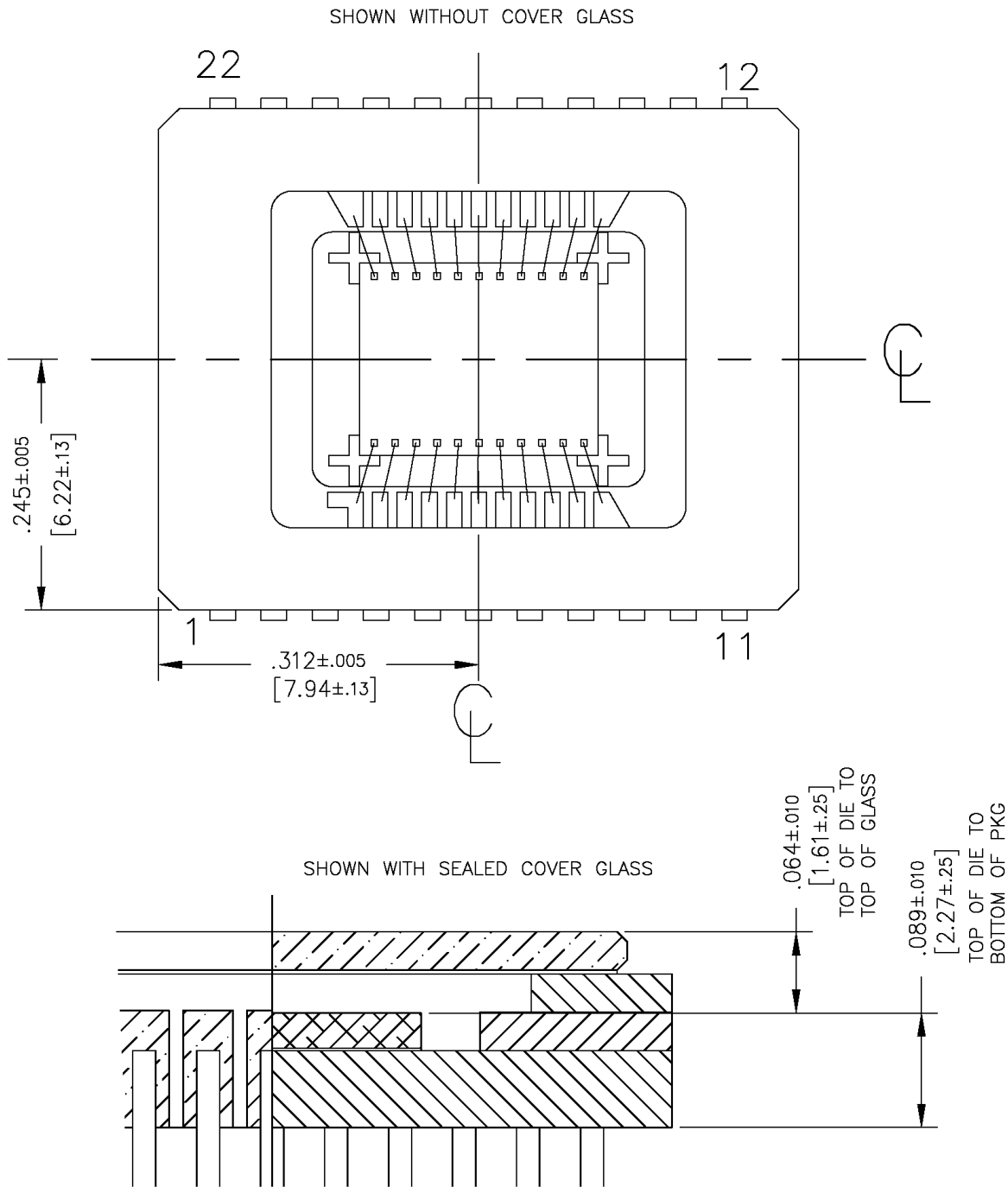

Figure 22: Die to Package Alignment

Notes:

1. Units: IN [mm]
2. Center of image area is offset from center of package by (0.00, 0.00) IN nominal.
3. Die is aligned within ± 1 degree of any package cavity edge.



GLASS

Clear Cover Glass

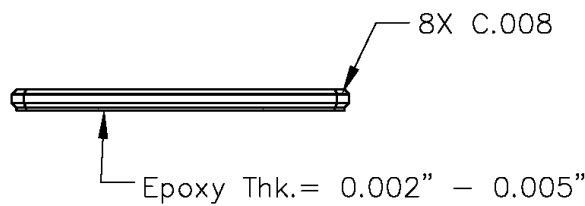
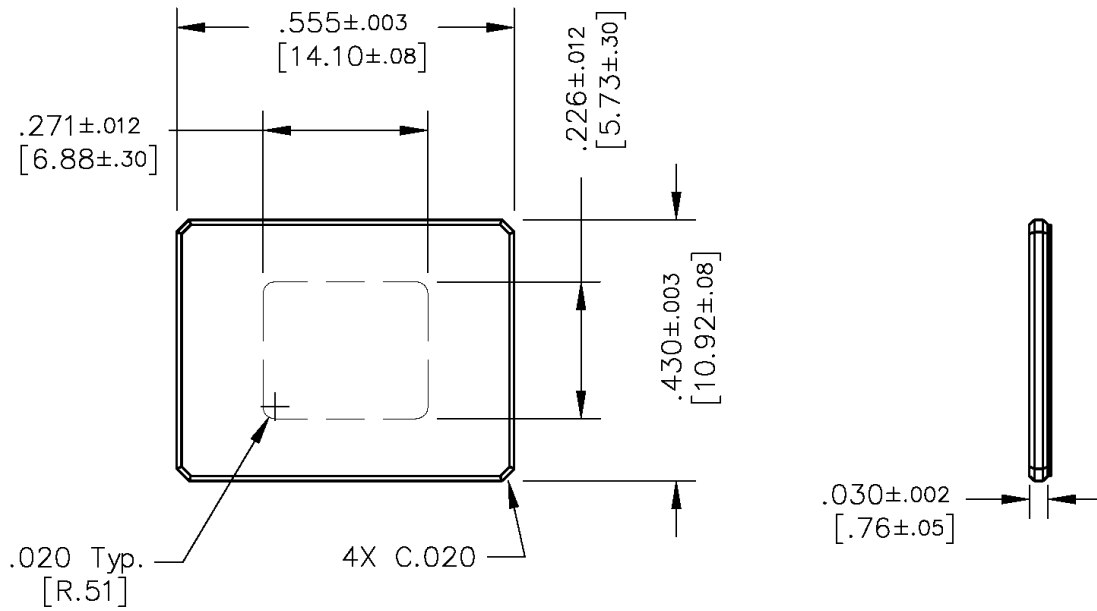

Figure 23: Glass Drawing

Notes:

1. Substrate: Schott D-263T eco or equivalent.
2. Units: Inch [mm].
3. Top and Bottom edge chamfers = 0.008 [0.20].
4. Corner chamfers = 0.020 [0.50].
5. Dust, scratch, dig specification: 10 microns max.



Quartz Cover Glass

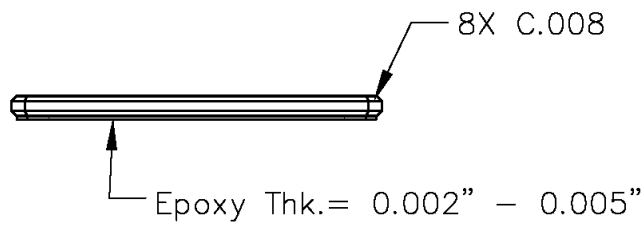
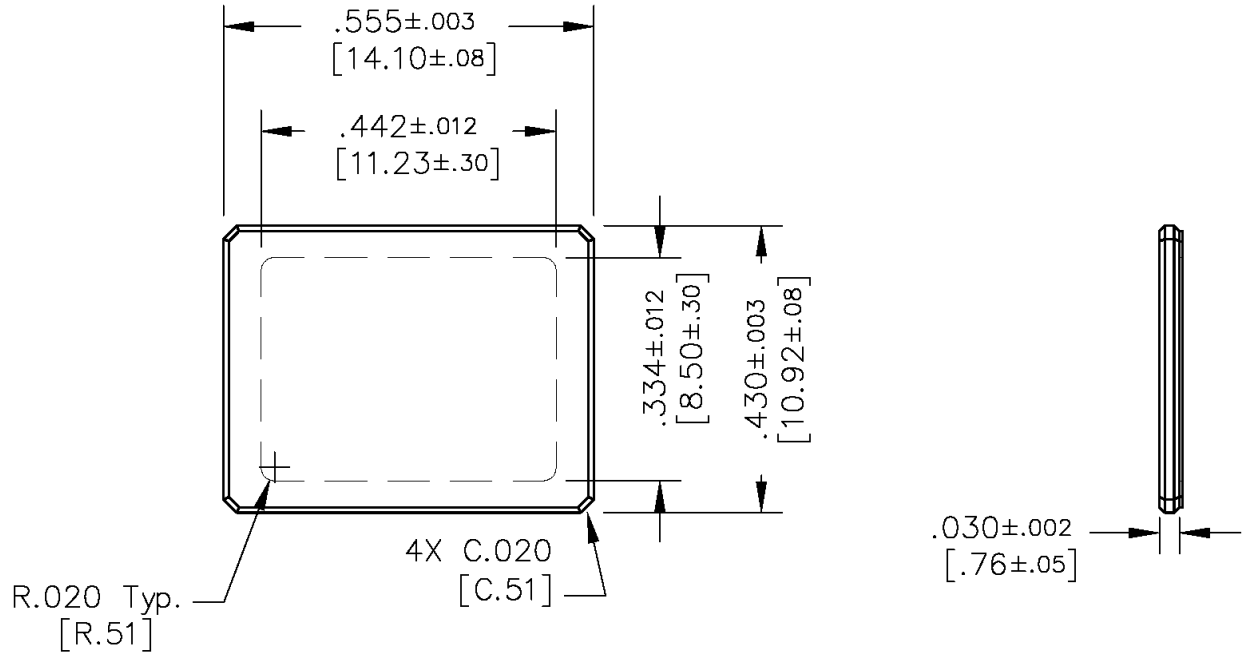

Figure 24: Quartz Cover Glass

Notes:

1. Substrate: SK1300.
2. Units: Inch [mm].
3. Top and Bottom edge chamfers = 0.008 [0.20].
4. Corner chamfers = 0.020 [0.50].
5. Dust, scratch, dig specification: 10 microns max.



GLASS TRANSMISSION

Clear Cover Glass

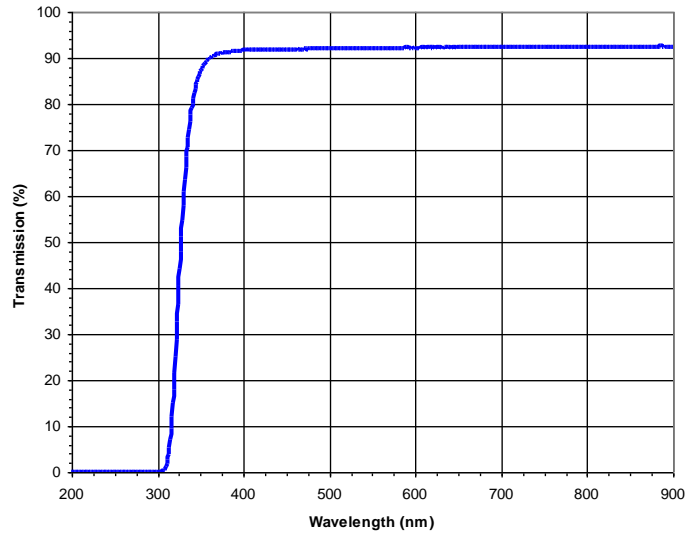

Figure 25: Clear Cover Glass Transmission

Quartz Cover Glass

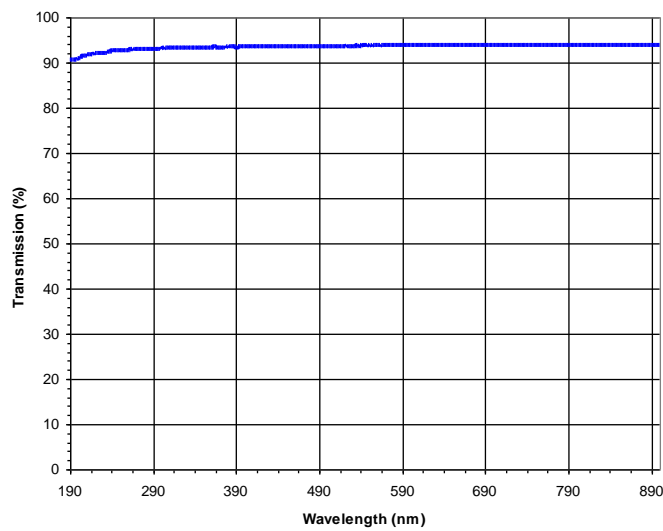

Figure 26: Quartz Cover Glass Transmission



Quality Assurance and Reliability

QUALITY AND RELIABILITY

All image sensors conform to the specifications stated in this document. This is accomplished through a combination of statistical process control and visual inspection and electrical testing at key points of the manufacturing process, using industry standard methods. Information concerning the quality assurance and reliability testing procedures and results are available from ON Semiconductor upon request. For further information refer to Application Note *Quality and Reliability*.

REPLACEMENT

All devices are warranted against failure in accordance with the *Terms of Sale*. Devices that fail due to mechanical and electrical damage caused by the customer will not be replaced.

LIABILITY OF THE SUPPLIER

A reject is defined as an image sensor that does not meet all of the specifications in this document upon receipt by the customer. Product liability is limited to the cost of the defective item, as defined in the *Terms of Sale*.

LIABILITY OF THE CUSTOMER

Damage from mishandling (scratches or breakage), electrostatic discharge (ESD), or other electrical misuse of the device beyond the stated operating or storage limits, which occurred after receipt of the sensor by the customer, shall be the responsibility of the customer.

TEST DATA RETENTION

Image sensors shall have an identifying number traceable to a test data file. Test data shall be kept for a period of 2 years after date of delivery.

MECHANICAL

The device assembly drawing is provided as a reference.

ON Semiconductor reserves the right to change any information contained herein without notice. All information furnished by ON Semiconductor is believed to be accurate.

Life Support Applications Policy

ON Semiconductor image sensors are not authorized for and should not be used within Life Support Systems without the specific written consent of ON Semiconductor.



Revision Changes

MTD/PS-0714

Revision Number	Description of Changes
1.0	<ul style="list-style-type: none"> Initial formal release
1.1	<ul style="list-style-type: none"> Page 26 – Removed caution for cover glass protective tape. The use of the protective tape has been discontinued. Page 48 – Removed note under Cover Glass Care and Cleanliness section that referred to cover glass protective tape.
2.0	<ul style="list-style-type: none"> Updated format Pages 13 and 18 – Included defect definitions. Pages 48, 49, 50 and 51 – Updated package and cover glass drawings. Page 54 – Updated ordering information section.
3.0	<ul style="list-style-type: none"> Updated Summary Specification page Moved and updated Ordering Information page Updated Monochrome with Microlens Quantum Efficiency graph Clarified Figure 7 title Updated Storage and Handling section Added cover glass protective tape note to Cover Glass Care and Cleanliness Section. Tape use was never discontinued as noted in revision 1.1 change Improved legibility of package and cover glass drawings Updated Quality Assurance and Reliability section
4.0	<ul style="list-style-type: none"> Corrected all KAI-340-ABA Product Name descriptions to KAI-340-ABB in Ordering Information table
5.0	<ul style="list-style-type: none"> Added part number 4H2143 KAI-0340-ABB-CB-A2-Single (Monochrome, Telecentric Microlens, CERDIP Package (sidebrazed), Clear Cover Glass, no coatings, Grade 2, Single Output) to the Ordering Information table Added Defect Definitions table for part number part number 4H2143 KAI-0340-ABB-CB-A2-Single, allowing up to 10 Major bright field defective pixel defects Added the note "Refer to Application Note <i>Using Interline CCD Image Sensors in High Intensity Visible Lighting Conditions</i>" to the following sections <ul style="list-style-type: none"> DC Bias Operating Conditions AC Operating Conditions Storage and Handling Changed clear cover glass material to D263T eco or equivalent

PS-0024

Revision Number	Description of Changes
1.0	<ul style="list-style-type: none"> Initial release with new document number, updated branding and document template Updated <i>Storage and Handling</i> and <i>Quality Assurance and Reliability</i> sections Reorganized structure for consistency with other Interline Transfer CCD documents
1.1	<ul style="list-style-type: none"> Updated branding

ON Semiconductor and ON are registered trademarks of Semiconductor Components Industries, LLC (SCILLC). SCILLC owns the rights to a number of patents, trademarks, copyrights, trade secrets, and other intellectual property. A listing of SCILLC's product/patent coverage may be accessed at www.onsemi.com/site/pdf/Patent-Marking.pdf. SCILLC reserves the right to make changes without further notice to any products herein. SCILLC makes no warranty, representation or guarantee regarding the suitability of its products for any particular purpose, nor does SCILLC assume any liability arising out of the application or use of any product or circuit, and specifically disclaims any and all liability, including without limitation special, consequential or incidental damages. "Typical" parameters which may be provided in SCILLC data sheets and/or specifications can and do vary in different applications and actual performance may vary over time. All operating parameters, including "Typicals" must be validated for each customer application by customer's technical experts. SCILLC does not convey any license under its patent rights nor the rights of others. SCILLC products are not designed, intended, or authorized for use as components in systems intended for surgical implant into the body, or other applications intended to support or sustain life, or for any other application in which the failure of the SCILLC product could create a situation where personal injury or death may occur. Should Buyer purchase or use SCILLC products for any such unintended or unauthorized application, Buyer shall indemnify and hold SCILLC and its officers, employees, subsidiaries, affiliates, and distributors harmless against all claims, costs, damages, and expenses, and reasonable attorney fees arising out of, directly or indirectly, any claim of personal injury or death associated with such unintended or unauthorized use, even if such claim alleges that SCILLC was negligent regarding the design or manufacture of the part. SCILLC is an Equal Opportunity/Affirmative Action Employer. This literature is subject to all applicable copyright laws and is not for resale in any manner.

PUBLICATION ORDERING INFORMATION

LITERATURE FULFILLMENT:

Literature Distribution Center for ON Semiconductor
P.O. Box 5163, Denver, Colorado 80217 USA
Phone: 303-675-2175 or 800-344-3860 Toll Free USA/Canada
Fax: 303-675-2176 or 800-344-3867 Toll Free USA/Canada
Email: orderlit@onsemi.com

N. American Technical Support: 800-282-9855 Toll Free
USA/Canada

Europe, Middle East and Africa Technical Support:
Phone: 421 33 790 2910

Japan Customer Focus Center
Phone: 81-3-5817-1050

ON Semiconductor Website: www.onsemi.com

Order Literature: <http://www.onsemi.com/orderlit>

For additional information, please contact your local Sales Representative